

# ROCKLAND<sup>®</sup>

Equipment Guide

## DO MORE.



**ALLIED EQUIPMENT FOR:**

**EXCAVATORS | LOADERS | DOZERS | GRADERS  
TELEHANDLERS | HAUL TRUCKS | SKID STEERS**



# HELPING YOU DO MORE IS OUR MISSION.

The right attachment makes your machine the best tool for the job at hand. Countless hours and dollars can be saved by improving productivity on the job. If you can do more every day, you can make more every day. That's our mission. To help you do more.

Rockland tools empower equipment operators to handle material easier, safer, and more productively. Jobs get done faster. Your company gets a better return on investment. And, because Rockland products are backed by the industries best warranties, you have peace of mind that downtime will be minimized along the way.

If you're an equipment dealer, Rockland helps you find ways for your customers to do more. Be it because our tools increase productivity, solve a unique customer problem, are built to last, or ship on time, every time. This keeps your customers satisfied and coming back again and again for your service and advice.

But that's not all. We believe that supporting our dealers isn't just about building great products, it's about also offering dealers the very best in services and programs that help dealers earn more, inventory less, and satisfy customers who expect world class service, short lead times, and customization.

That's why in addition to offering over 200 products, we are the only construction equipment company to offer guaranteed ship dates with cash, Rapid service, inventory management programs, hundreds of attachments in stock, real time quoting 24/7, free color matching, custom logos, dealer training, and many other programs. Please ask your Rockland account manager about these and other programs that we offer.

We know our success is connected directly to your success and look forward to discussing what we can do to help you do more in the future. Thank you for considering working with Rockland.

## WHERE WE COME FROM...

In the late 1940s an equipment salesman named Tom Billings had a problem. He couldn't find a land clearing rake that would last. Tom decided to take matters into his own hands and in 1951 built the first Rockland RF-3 rake behind a gas station.

The RF-3 was a land clearing rake with reversible teeth and a lifetime warranty. Tom quickly sold the first and then sold more. In 1953 Rockland was born. Tom continued to focus on quality and designing new products that helped machines do more. The rest is history.

Today Rockland offers over 200 products, holds over 40 patents, and produces products for OEMs and construction machinery dealers around the world. During this journey Rockland designed and built the first wheel loader rock bucket, the world's largest dozer blade, and pioneered ideas that are now industry norms such as horizontal wear strips on excavator buckets, using high strength steel in place of cast lips, and hydraulic thumbs.

A lot has changed since Tom's first rake, but the most important things haven't. We still design our products one at a time. We still manufacture in the USA. We still offer the best warranty. We still guarantee ship dates. We still know our job is to get better and help our customers do more every day. And most of all, we still are, and will always be, thankful for your business.



Bo Pratt, President & CEO of Rockland Manufacturing

# EXCLUSIVE BENEFITS FOR DEALERS

- ✓ Over 200 products
- ✓ Rockski Quoting App
- ✓ Real-Time Inventory Online
- ✓ Parts and Service
- ✓ Guaranteed Ship Dates, Backed by Cash
- ✓ Rockland Rapid
- ✓ Quick Ship Program
- ✓ No Restock Fees on Standard Items
- ✓ Lifetime Warranties
- ✓ Industry's Best Warranties
- ✓ Loyalty Programs
- ✓ Dealer Sales Training

## OUR WARRANTY POLICY

Rockland warranties cover any failure due to defective materials, design, or workmanship.

Here is a quick reference list:



**LIFETIME**  
RF-3 Rake  
HD-V Rock Buckets  
HD-S Rock Buckets  
SDQ Quarry Buckets



**1 YEAR | 2,000 HOURS**  
Beach Cleaners  
Rotoveyers



**2 YEARS | 4,000 HOURS**  
All other products



# THE RIGHT TOOLS FOR ANY JOB

<b>ABOUT ROCKLAND</b> .....	2	<b>LOADER EQUIPMENT</b> .....	38
<b>WHY ROCKLAND?</b> .....	3	<b>Buckets</b> .....	40
<b>EXCAVATOR EQUIPMENT</b> .....	6	<b>Feature Comparison Guide</b> .....	42
<b>Buckets</b> .....	8	<b>General Purpose Components &amp; Terminology</b> ...	45
<b>Excavator Application Guide</b> .....	10	<b>Options</b> .....	60
<b>Excavator Components &amp; Terminology</b> .....	9	<b>Understanding Capacity Rating Guide</b> .....	41
Ditch Cleaning .....	12	Aggregate .....	48
Heavy-Duty .....	11	Coal Digging .....	43
Krypto Klaw™ .....	26	Coal Loading .....	43
Krypto Klaw™ Skeleton .....	26	CS Cooling Slag .....	47
Pavement Removal .....	11	Demolition .....	49
Rock Ripping .....	13	Ejector .....	53
Rock Tine .....	13	GPH Material Handling .....	44
Severe Service .....	11	GPX General Purpose Excavation .....	44
Tilt .....	12	GPC General Purpose with Clamps .....	64
Trapezoid .....	12	Light Material .....	43
V-Bottom Rock .....	13	LBC Light Material with Clamps .....	64
<b>Grapples</b> .....	16	MHS Molten Slag .....	46
H23 Severe Service .....	16	MP Multi-Purpose – 4-in-1 .....	49
L45 Light Material .....	16	RL Single Cylinder Rollout .....	53
<b>Thumbs</b> .....	18	RL2 Dual Cylinder Rollout .....	54
<b>Feature Comparison</b> .....	18	Heavy-Duty Rock .....	57
BTS Solid Strut .....	21	Rock Tine .....	57
BTS-W Wilde Solid Strut .....	21	SD Digging .....	47
BTH Hydraulic .....	20	SDQ Super-Duty Quarry .....	58
BTH-W Wide Hydraulic .....	20	Side Dump .....	49
Pin-Mounted .....	22	SL Slag Loading .....	47
Progressive Link .....	24	SO Slip-On .....	52
<b>Couplers</b> .....	34	SOHD Slip-On High Dump .....	52
HKR .....	35	Trash Handling .....	50
HKRT Tilting .....	35	Trash Handling MPL Multi-Purpose .....	50
<b>Pulverizers and Splitters</b> .....	32	Transfer Station .....	50
Clearing Splitter .....	33	Woodchip .....	52
Concrete Pulverizer .....	17	<b>Couplers</b> .....	65
Stump Splitter .....	33	Manual Rocklock® .....	65
<b>Compaction and Land Clearing</b> .....	30	Hydraulic Rocklock® .....	65
Compaction Wheels .....	37	<b>Forks</b> .....	66
Excavator Rake .....	30	Bucket – Shaft Mounted .....	67
Excavator Ripper .....	31	Car Body .....	67
Rhino Stump Puller .....	31	Construction – Heavy-Duty .....	68
Thompson Slope Packer® .....	36	Construction – Utility .....	68
		Log .....	69
		Pallet .....	69
		Rock .....	69

<b>Grapples</b> .....	70
Brush Handling .....	74
Cleanup .....	74
LF Log .....	71
Millyard .....	72
Millyard High-Capacity .....	72
Peeler .....	71
Pipe .....	75
SG Sorting .....	73
SGG General Purpose Sorting .....	73
Tire .....	75
Tree Length Log .....	73
<b>Rakes</b> .....	76
Loader Rake .....	77
Loader Rake With Clamps .....	77
<b>Snow Attachments</b> .....	51
Basket .....	51
Bucket .....	51
Pusher .....	51
<b>DOZER EQUIPMENT</b> .....	78
<b>Blades</b> .....	80
Angle, C-Frame, & Brace Group .....	81
Coal .....	81
Dozer Slope Board .....	79
Landfill .....	82
Reclamation .....	82
SA-4 Shear .....	83
Semi-U .....	81
VR Clearing .....	83
Woodchip .....	82
<b>Ripper</b> .....	79
Multi-shank .....	79
<b>Rakes</b> .....	84
Blade Rake .....	85
Multi-Application .....	85
RF-3 Severe Service .....	85
SR Stacking .....	85
<b>TRUCKS</b> .....	86
Tuffgate® Tailgate .....	87
<b>GRADERS</b> .....	88
Road King Sloper® .....	89

**CUSTOM ATTACHMENTS** .....90

**WEIGHTS & CONVERSIONS** .....92

**CONTACT INFORMATION** .....93



**Made in the USA**



**Made in the USA 7**

# EXCAVATOR EQUIPMENT



**Pg. 11**  
**Heavy-Duty Bucket**



**Pg. 11**  
**Severe Service Bucket**



**Pg. 12**  
**Trapezoid Bucket**



**Pg. 13**  
**Rock Ripping Bucket**



**Pg. 13**  
**Rock Tine Bucket**



**Pg. 17**  
**Concrete Pulverizer**



**Pg. 20**  
**BTH Hydraulic Thumb**



**Pg. 21**  
**BTS Solid Strut Thumb**



**Pg. 24**  
**Progressive Link Thumb**



**Pg. 26**  
**Krypto Klaw™**

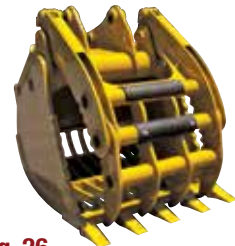

**Pg. 26**  
**Krypto Klaw™**  
**Skeleton Bucket**



**Pg. 33**  
**Stump Splitter**



**Pg. 33**  
**Clearing Splitter**



**Pg. 35**  
**HKR Excavator Coupler**



**Pg. 11**  
**Pavement Removal Bucket**



**Pg. 12**  
**Tilt Bucket**

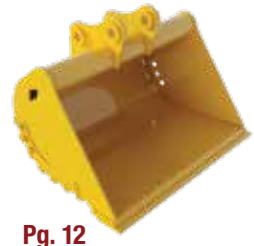

**Pg. 12**  
**Ditch Cleaning Bucket**



**Pg. 13**  
**V-Bottom Rock Bucket**



**Pg. 16**  
**H23 Severe Service Grapple**



**Pg. 16**  
**L45 Light Material Grapple**



**Pg. 20**  
**BTH-W Wide Hydraulic Thumb**



**Pg. 21**  
**BTS-W Wide Solid Strut Thumb**



**Pg. 22**  
**Pin-Mounted Thumb**



**Pg. 30**  
**Excavator Rake**



**Pg. 31**  
**Ripper**



**Pg. 31**  
**Rhino Stump Puller**



**Pg. 35**  
**HKRT Tilt Coupler**



**Pg. 36**  
**Thompson Slope Packer®**



**Pg. 37**  
**Compaction Wheels**



# EXCAVATOR BUCKETS

Doing The Job Right Starts With The Right Bucket.



**EXCAVATING SUCCESS STARTS** with the right bucket. Rockland excavator buckets are designed to deliver efficient digging performance and are built to last. Our Buckets feature full-width torque tubes or flanges to remove bucket twist and deliver superior bracket support. Abrasion Resistant AR400 Wear Plate is standard on all high wear areas to guarantee superior bucket life. Contractors around the world have come to rely on our value adding features. Rockland excavator buckets are available for minis to mining and are built to suit many applications.

**"We buy Rockland Excavator Buckets because we know  
Rockland guarantees satisfaction."**

**– Texas Contractor**





# EXCAVATOR BUCKET BREAKDOWN

## Heavy-Duty Bucket

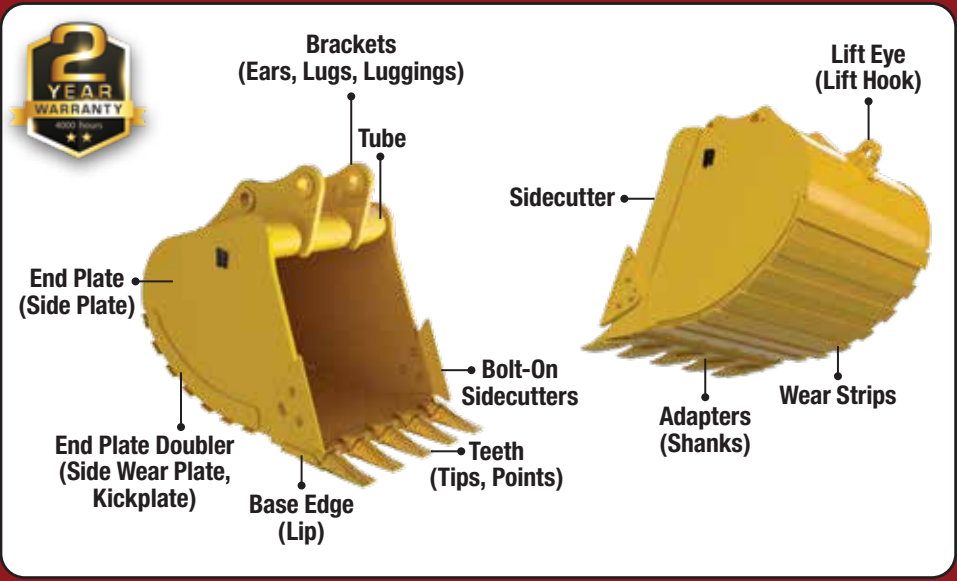

## Severe Service Bucket

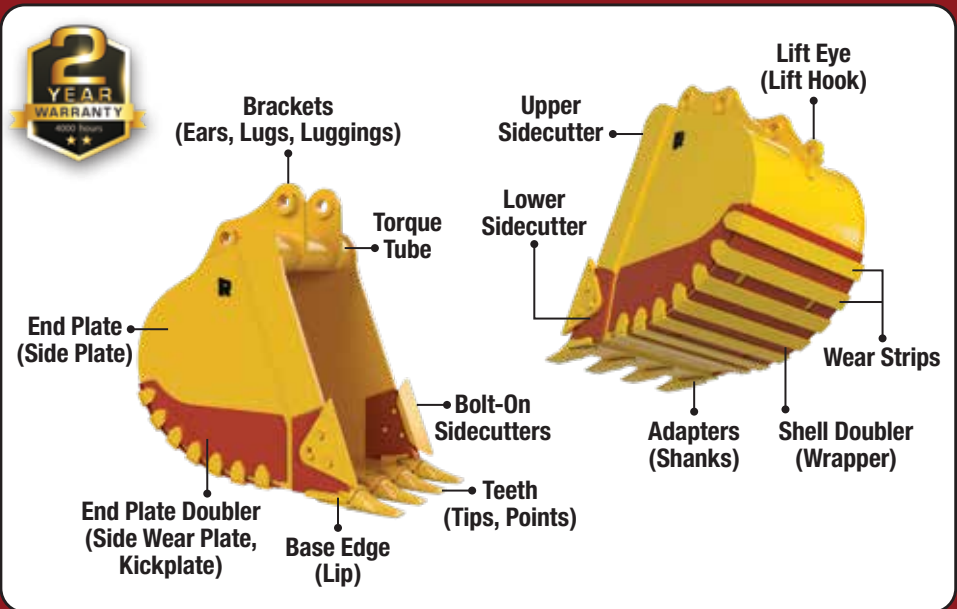

# BUCKET APPLICATION GUIDE

## Which Bucket Is Best For My Soil Type?

	Heavy-Duty Bucket	Ditch Cleaning Bucket	Severe Service Bucket	Rock Ripping Bucket	V-Bottom Rock Bucket
Angular Gravel	✓	✓	✓		
Caliche			✓	✓	✓
Clay	✓	✓			
Clay, Loam	✓	✓			
Clay, Dry	✓	✓		✓	
Clay, Natural Bed	✓	✓			
Clay, Wet	✓	✓			
Clay and Gravel	✓	✓			
Coal	✓	✓			
Anthracite	✓	✓	✓		
Bituminous	✓	✓	✓		
Decompressed Rock	✓		✓	✓	✓
Earth, Dry	✓	✓			
Earth, Loam	✓	✓			
Earth, Wet Excavated	✓	✓			
Glacial Till	✓	✓	✓	✓	
Gravel	✓	✓	✓	✓	
Limestone, Blasted	✓	✓	✓		
Limestone, Crushed	✓	✓	✓		
Loam	✓	✓			
Loamy Sand	✓	✓			
Sand	✓		✓	✓	✓
Sandstone			✓	✓	✓
Sandy Clay	✓	✓			
Sandy Clay Loam	✓	✓			
Sandy Loams	✓	✓			
Shale	✓	✓	✓	✓	
Silt	✓	✓			
Silt, Loam	✓	✓			
Silty Clay	✓	✓			
Silty Clay Loam	✓	✓			
Slag	✓		✓		
Slate	✓		✓	✓	
Stone, Crushed	✓		✓	✓	



## Heavy-Duty Bucket

*Built to perform day after day.*

- Get full loads every pass.
- Ideal for tough excavation work.
- Rock Strips reduce shell wear.
- Dual-radius shell and tapered end plates deliver superior load release.
- Available with bolt-on sidecutters, vertical shrouds, and segments.
- Available with points and adapters of your choice.
- Custom wear plates, logos, and other features available upon request.



## Severe Service Bucket

*For tough rock work.*

- Reinforced high-strength design guarantees a long life and great performance.
- Standard shell doubler and rock strips protect bucket shell from wear.
- Available with bolt-on sidecutters, vertical shrouds, and segments.
- Available with points and adapters of your choice.
- Custom wear plates, logos, and other features available upon request.



## Concrete/Pavement Removal Bucket

*The best way to efficiently break and load concrete slabs.*

- Unique C-shape speeds the removal of concrete and pavement slabs.
- Much more efficient than chasing pavement pieces with an ordinary bucket.
- Ribbed design adds rigidity and minimizes wear on the bucket shell.
- Available with points and adapters of your choice.
- Custom wear plates, logos, and other features available upon request.



## Tilt Bucket

*Speed up the process by getting the right slope on the first cut.*

- Two designs available. Standard Duty for most applications or Severe Duty for grading in tough terrain.
- Up to 90° of tilt, 45° in each direction.
- Heavy-duty, cushioned tilt cylinders for maximum control and articulation.
- Common sense hose routing and easy-to-reach grease fittings.
- Available in multiple widths and sizes to suit any job.
- Both designs come equipped with bolt-on cutting edges, wear strips, and drain holes as standard.
- Severe Duty bucket adds cylinder guards plus an enhanced wear package everywhere you need it most.
- Custom wear plates, logos, and other features available upon request.

**Standard  
Duty**



**Severe  
Duty**



## Ditch Cleaning Bucket

*Perfect for cleaning trenches, grading, and finishing work.*

- Wide, shallow design for quick, easy ditch cleaning.
- Available with or without drain holes.
- Manufactured out of weight saving high-strength alloy steel - ensuring years of dependable service while reducing the bucket's weight.
- Equipped with reversible bolt-on cutting edges.
- No-nonsense two year, 4,000 hour warranty.



## Trapezoid Bucket

*Ideal for pipeline and trenching work.*

- Creates trench profile with narrow floor and safe side slope angle.
- Eliminates wasted effort and excess backfill.
- Available in virtually any width and slope angle.
- Available with bolt-on edges or points and adapters of your choice.
- Available with custom logos and other features upon request.



## Rock Ripping Bucket

### *Rip first, then dig!*

- A serious bucket for seriously hard digging!
- Built-in rippers fracture most rocks and increase output on every pass.
- The modified spade-nose lip and the staggered teeth create easier, faster penetration.
- High-strength alloy steel construction for years of dependable performance.
- Available with built-in sidecutters, full-body wear plates, and points and adapters of your choice.



## Rock Tine Bucket

### *Load what you need, leave the rest.*

- Easily separate material on every pass.
- Sort or load to the size you need.
- Available with your choice of tine spacing.
- Available with points and adapters and bolt-on sidecutters of your choice.
- Custom logos and other features upon request.

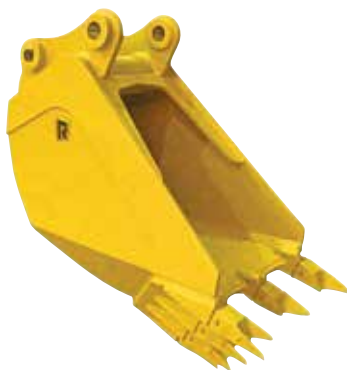

## V-Bottom Rock Bucket

### *Perfect for tightly packed, frozen, or rocky soils.*

- Maximizes digging performance in frozen earth, caliche, limestone, and shale.
- The specialized bucket profile and v-style teeth outproduce standard buckets in frozen and rocky soils.
- High-strength alloy steel design ensures maximum abrasion resistance.
- Custom logos and other features upon request.







# AN EXCAVATOR GRAPPLE

For Every Application



**ROCKLAND EXCAVATOR GRAPPLES** are built with the same dedication and quality that made our other products famous. Whether it's demolition, loading rock, clearing land, or handling trash, Rockland Grapples will help you get the job done right.

## H23 Severe Service Grapple

*For rough tough jobs, choose this grapple!*

- Built for heavy-duty demolition work, rock handling, and tough land clearing applications.
- Narrow two-tine top clamp and three-tine bottom clamp maximizes gripping and ripping power.
- Independent pivot pins eliminate grapple halves from separating when removed - saving time and increasing safety during install and removal.
- Easily used with an excavator coupler due to independent pivot design.
- Reinforced wear plates on all grapple tines ensure years of dependable performance.
- Available with custom wear packages, hardfacing, and other options upon request.



## L45 Light Material Grapple

*Ideal for handling light scrap, trash, or bulky material!*

- Four-tine top clamp and five-tine bottom clamp moves large loads and maximizes production per pass.
- Abrasion resistant alloy wear plates at the front and rear of each tine guarantees years of dependable performance.
- Independent pivot pins eliminate grapple halves from separating when removed - saving time and increasing safety during install and removal.





## Concrete Pulverizer

*Quickly reduce massive concrete slabs and chunks to aggregate!*

- Installs easily and requires no additional hydraulics.
- Separate concrete and rebar and turn them into recyclable, profitable materials.
- Crushing jaws pivot on a heavy-duty, heat-treated pivot pin supported by heavy-duty bushings guaranteeing years of dependable performance.
- More cost-efficient than a hammer and easier on your machine.
- Additional hard facing, custom jaw designs, and other options available upon request.

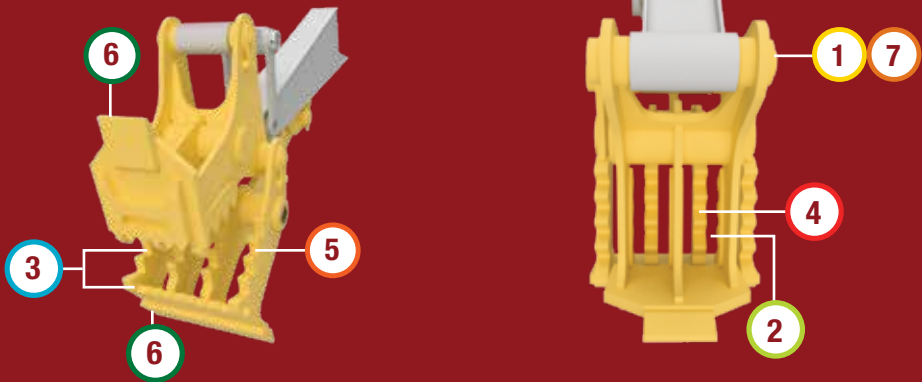

## FEATURES THAT MAKE A DIFFERENCE

- 1 Simple and easy installation. Pins in place of normal bucket, strut bracket welds to underside of the stick. No extra hoses or valves required!
- 2 Open jaw design promotes material flow-through and prevents material impaction.
- 3 Serrated pinch plates pull and sort rebar and other recyclable materials from reinforced concrete.
- 4 Choose from two different jaw configurations; 3 over 4 jaw for greater crushing force on thicker materials, or 4 over 5 jaw for finer material output.
- 5 Equipped with weld-in, high-strength, abrasion resistant AR500 replaceable teeth, and case-hardened pins and bushings for years of dependable service.
- 6 Equipped with weld-on, half-arrow cutting edges on nose and heel plates for scraping, lifting, and flipping concrete slabs, walls, bridge decks, and asphalt.
- 7 Available for coupler or pin-on configurations.





# THUMBS FOR



## **BTH Hydraulic**

- Narrow design keeps weight to a minimum and provides positive three-point pickup.
- Patented mechanical thumb lock eliminates downdrift and keeps thumb locked against the stick.
- Installs easily, saving time by eliminating setting and welding of loose parts.



## **BTH-W Wide Hydraulic**

- Ideal for handling fine debris & bulky, loose materials.
- Thumb tines mesh with most common bucket widths.
- Installs easily and saves time by eliminating setting and welding of loose parts.
- Patented mechanical thumb lock eliminates downdrift and keeps thumb locked against the stick.



## **BTS Solid Strut**

- Narrow design keeps weight to a minimum and provides positive three-point pickup.
- Manual thumb positioning for operators who don't re-position often or don't have auxiliary hydraulics.
- Mechanical pin stores thumb out of the way when not in use.
- Installs easily, saving time by eliminating setting and welding of loose parts.

# EVERY APPLICATION



## BTS-W Wide Solid Strut

- Manual thumb positioning. For operators who don't re-position often or don't have auxiliary hydraulics.
- Thumb tines mesh with most common bucket widths.
- Mechanical pin stores thumb out of the way when not in use.
- Installs easily, saving time by eliminating setting and welding of loose parts.



## Pin-Mounted

- 120° rotation - Positive load control through 65-75% of bucket rotation.
- Thumb tines mesh with bucket teeth.
- Fully hydraulic allowing precise control of thumb.
- Installs easily, saving time by eliminating setting and welding of loose parts.
- Built-in mechanical storage pin and on board pin holder for when thumb is not in use.



## Progressive Link

- 180° rotation - Positive load control through nearly 100% of bucket rotation.
- Ideal for when precise material placement is required.
- Inner curve profile naturally cradles material.
- Installs easily, saving time by eliminating setting and welding of loose parts.
- Built-in mechanical storage pin and on board pin holder for when thumb is not in use.

**FACTOID: Rockland pioneered using thumbs on excavators!**



# BTH/BTHW HYDRAULIC STICK MOUNTED THUMBS

## *The simple hydraulic thumb*

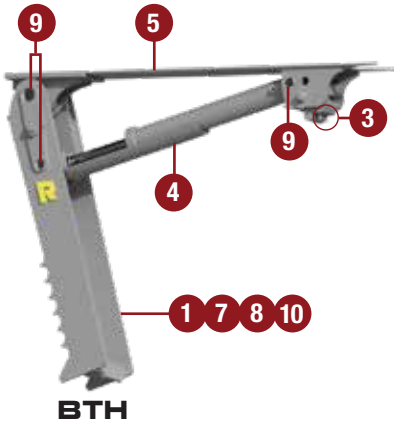

**BTH**

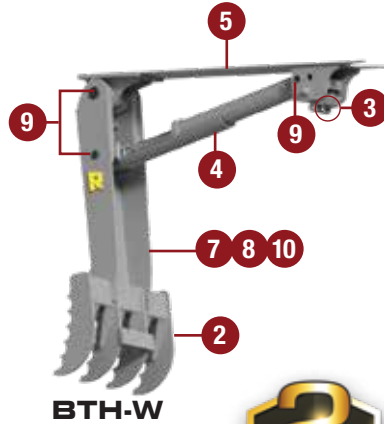

**BTH-W**



- 1 The BTH narrow design provides fast, positive 3-point pickup.
- 2 The BTH-W wide, multi-tine design meshes with common bucket teeth and is ideal for handling bulky material.
- 3 Both BTH and BTH-W thumb feature the patented thumb lock, eliminating downdrift. This unique mechanical lock eliminates downdrift and keeps it locked against the stick. When the thumb is needed, the lock releases automatically. U.S. Patent 6,209,237B1
- 4 Both BTH and BTH-W thumbs have a patented, built-in cylinder rod guard that prevents cylinder damage. U.S. Patent 6,843,005B2
- 5 Both BTH and BTH-W thumbs are easily installed. All Rockland thumbs ship fully assembled and quickly mount on the underside of the stick.
- 6 Both BTH and BTH-W thumbs are both IN STOCK and ready for quick shipment!
- 7 Both BTH and BTH-W thumbs feature a compact storage position for easy machine transportation. Our thumbs will never hit your boom or need to be removed to move the machine.
- 8 Both BTH and BTH-W thumbs are available in standard and coupler length for use with or without a coupler.
- 9 Both BTH and BTH-W thumbs have easily replaceable, heat-treated pins and bushings.
- 10 Both BTH and BTH-W thumbs are constructed from high-strength alloy steel, keeping thumb weight to a minimum. This saves fuel and money on every pass.

# BTS/BTS-W SOLID STRUT THUMBS

*The most economical thumb option!*

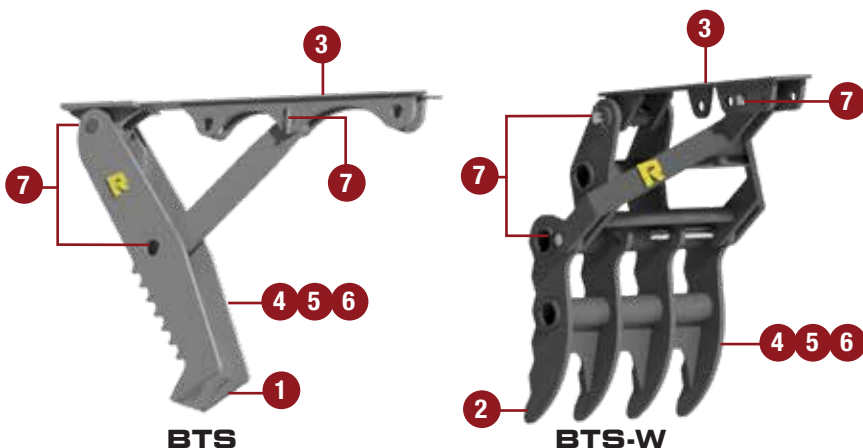

- 1 The BTS narrow thumb provides fast, positive 3-point pickup.
- 2 The BTS-W wide, multi-tine design meshes with most common bucket teeth and is ideal for bulky materials.
- 3 Both BTS and BTS-W thumbs are easily installed. All Rockland thumbs ship fully assembled and quickly mount on the underside of the stick.
- 4 Both BTS and BTS-W thumbs feature a compact storage position for easy machine transportation. Our thumbs will never hit your boom or need to be removed to move the machine.
- 5 Both BTS and BTS-W thumbs are available in standard or coupler length for use with or without a coupler.
- 6 Both BTS and BTS-W thumbs are constructed from high-strength, weight-saving alloy steel, keeping thumb weight to a minimum.
- 7 Both BTS and BTS-W thumbs have easily replaceable, heat-treated pins and bushings.



# PIN-MOUNTED THUMBS

**MORE ROTATION. EASY INSTALL.  
PRECISE PLACEMENT.**



## *Accurately handle material in all positions.*

- Precisely pick and place material.
- Keep load securely clamped when rotating the thumb and bucket.
- Up to 120° rotation.
- Lubricated, replaceable, heat-treated pins and bushings.
- Heavy-duty, dual-cushioned thumb cylinder.
- Cylinder transfer hose keeps jumper hoses shorter and less prone to damage.
- Matched to your bucket's teeth.
- Available to use on coupler or non-coupler set ups.
- Full mechanical locking pin prevents frustrating downdrift.

# WHY ROCKLAND PIN-MOUNTED THUMBS ARE THE BEST

Transfer hose keeps machine jumper lines shorter & less prone to damage. Available with hard lines if desired.

Heavy-duty, dual-cushioned, Rockland manufactured cylinder. Thumb follows 65% - 75% of the bucket rotation.

Built-in storage pin locks the thumb body in place when not in use, preventing hydraulic downdrift.

Lubricated, replaceable, heat-treated pins and bushings deliver years of dependable performance.

Thumb tines mesh with bucket teeth. Easily pick-up finer materials.

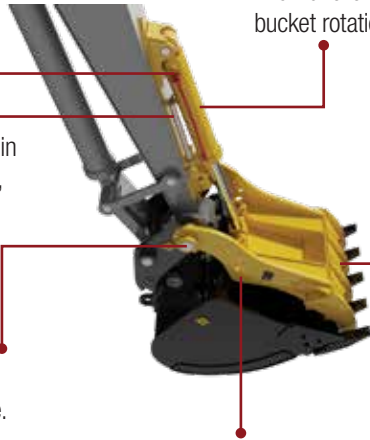

Curved thumb body profile cradles material. Built-in serrations hold material in place. Rigid box-frame construction withstands the toughest applications.

## WHAT THUMB ROTATION IS ALL ABOUT

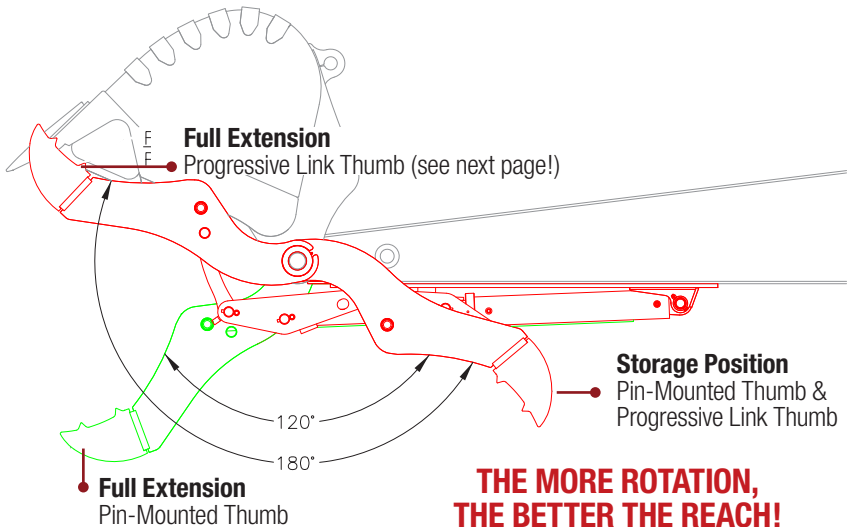

# PROGRESSIVE LINK THUMB

More Rotation. Easy Install. Built to Last.



*Precisely pick and place material even at maximum reach.*

- Precisely pick and place material.
- Keep load securely clamped when rotating the thumb and bucket.
- Progressive link increases rotation up to 180°.
- Fast & easy installation saves hours compared to other manufacturers. Eliminate modifying links and poor installs!
- Lubricated, replaceable, heat-treated pins and bushings.
- Heavy-duty, dual-cushioned thumb cylinder.
- Cylinder transfer hose keeps jumper hoses shorter and less prone to damage.
- Matched to your bucket's teeth.
- Backed by Rockland's no-nonsense, two year, 4,000 hour warranty.
- Full mechanical locking pin prevents frustrating downdrift.





# WHY ROCKLAND PROGRESSIVE LINK THUMBS ARE THE BEST

Transfer hose keeps machine jumper lines shorter & less prone to damage. Available with hard lines if desired.

Heavy-duty, dual-cushioned, Rockland manufactured cylinder.

Built-in storage pin locks the thumb body in place when not in use, preventing hydraulic downdrift.

Built-in thumb linkage eliminates modifying link pins and dramatically simplifies installation.

One piece mounting pad saves hours in installation time and eliminates common lineup issues and mistakes!

Heavy-duty thumb linkage delivers maximum thumb rotation. Pick and place with great precision!

Lubricated, replaceable, heat-treated pins and bushings deliver years of dependable performance.

Thumb tines mesh with bucket teeth. Easily pick up finer materials.

Curved thumb body profile cradles material. Built-in serrations hold material in place. Rigid box-frame construction withstands the toughest applications.

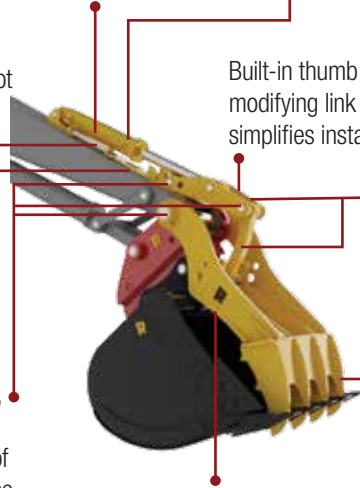

## WHAT THUMB ROTATION IS ALL ABOUT

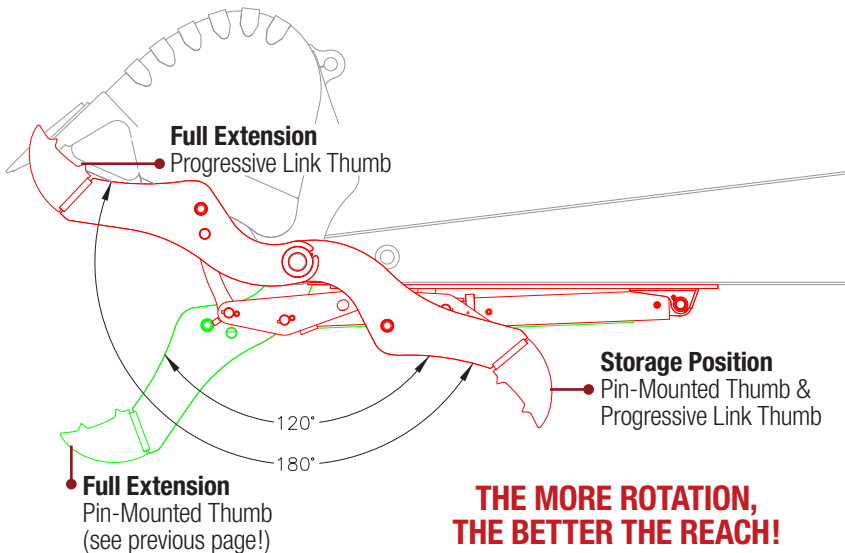

# PUT THE POWER OF "THE KLAW" TO WORK FOR YOU



**KRYPTO KLAW™**  
**DOES IT ALL** on tough demolition and land clearing jobs where strength and versatility are required. That's because the Krypto Klaw™ was designed with those jobs in mind. There is no better tool to have in your arsenal. Now you can dig, rip, grip, pull, and load all with the same tough tool!

## *The patented excavator tool that delivers unequalled versatility.*

- Operators can use 100% of the excavator's reach. Ideal for demolition, land clearing, pick, place, and ripping applications.
- Wide, dual-cylinder clamp delivers more clamping force than a bucket/thumb combination.
- The load stays tight while being positioned – operators do not have to operate the curl and thumb cylinders as they position the load increasing speed, safety, and accuracy.
- Easy to install! Pin on and connect hydraulic fittings. Perfect for multi-machine fleets!
- Wasted fuel and reduced capacity is eliminated. Quickly disconnect and lose the weight of the Krypto Klaw™ when it's not needed.
- All Krypto Klaw™ feature heavy-duty, dual-cushioned Rockland built cylinders. Bolt-on cylinder covers and rod guard sleeves are available for extreme applications.
- Available with an optional skeleton bucket bottom for easy sorting!
- Available with points and adapters of your choice.

**Krypto Klaw™**



**Krypto Klaw™  
Skeleton Bucket**

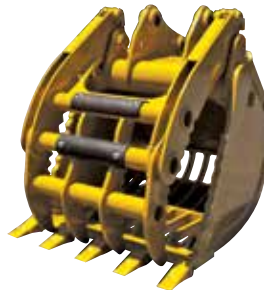

# THE ULTIMATE DEMOLITION TOOL

U.S. PATENT 7,617,619

Dual stick bumpers  
protect stick

External stops to  
protect cylinder  
in extension &  
retraction

High-strength abrasion  
resistant steel  
*All clamp tines.*

*Cutting edge & sidecutter  
insert for tough abuse.*

Rockland designed &  
built heavy-duty cylinders  
*Higher operating pressures,  
high quality seals &  
components, fully  
serviceable and in stock!*

O.D. & I.D. grease  
groove on all bushings

Heat-treated  
cylinder bushings.

Recessed grease zerks  
on cylinder rod/lug

Cylinder & Pivot Pins

*Induction hardened,  
chrome plated.*

High-strength abrasion  
resistant steel

*Shell doubler and  
wear strips.*







# ROCKLAND LAND CLEARING TOOLS

Make Land Clearing Easier.



**ROCKLAND EXCAVATOR LAND CLEARING TOOLS INCREASE PRODUCTIVITY.** These tools will outperform a bucket and quickly pay for themselves. They are designed to perform and built to last in the Rockland tradition.

When there is a lot of clearing to be done, equip your excavator with a Rockland clearing tool and get the job done faster.

## Excavator Rake

*Turn your excavator into an efficient land clearing machine.*

- Move debris & keep the soil where it's needed.
- Long, tough teeth are curved for maximum digging, sorting, and sifting.
- Multiple tine spacing options are available.
- Use with a Rockland thumb to quickly clear large, bulky loads.
- Custom logos and wear parts are available upon request.



## Excavator Ripper

*Break up dense, hard-packed material with ease!*

- Rips rock, pavement, or frozen ground by focusing all of the power of your excavator into a small area. Get big-time penetration and the ability to break up stubborn materials easily.
- Available for coupler and pin-on setups.
- Severe-duty designs with additional wear parts are available. (see photo below)
- Backed by Rockland's exclusive no-nonsense two year, 4,000 hour warranty.



**Standard  
Design**



**Severe Duty  
Excavator  
Ripper**

## Rhino Stump Puller

*The easiest way to remove stumps with an excavator!*

- Easily slice lateral roots with the abrasion resistant, sharpened blades.
- Curved shape speeds clearing and piling.
- Sharp front hooks split and lift debris easily.
- Available for use in coupler and pin-on setups.
- Backed by Rockland's exclusive no-nonsense two year, 4,000 hour warranty.



# ROCKLAND STUMP SPLITTERS

Get The Job Done



**ROCKLAND STUMP SPLITTERS** are built to work and work hard! Rockland stump splitters are being used in landfill and wood processing yards all over the country. They are easy to install, built tough, and deliver maximum splitting power, increasing efficiency and more stumps processed per hour!

**"My Rockland Stump Splitter gets the job done."**

**— Vermont Contractor**





## Stump Splitter

*Use the power of your excavator's curl cylinder to reduce stumps and wood debris.*

- Rugged & economical design harnesses the power of your excavator's curl cylinder. Additional stick plumbing not required!
- Equipped with custom links to provide maximum splitting power.
- Hardfacing on knives, oversized bushings, and heat-treated pins deliver years of dependable performance.
- Backed by Rockland's exclusive no-nonsense two year, 4,000 hour warranty.



## Clearing Splitter

*Grab, pull, backfill, shear, split, and load with one tool!*

- Ideal for operations that need to remove stumps, backfill, and precisely handle stumps and debris with an additional cylinder.
- Two massive ripper teeth pull stumps out of the ground quickly.
- As the stump is removed, the secondary cylinder is activated – splitting the stump in one swift motion. Operators then fill in the hole with the built-in backfill blade.
- Heavy-duty hydraulic cylinder delivers precise control, maximum splitting power, and increases productivity on stump removal jobs.
- All Clearing Splitters are equipped with heat-treat pins, hardened bushings, and hardfacing on the cutting knives.



# HKR EXCAVATOR COUPLER

**SIMPLE. SAFE. RELIABLE. VERSATILE.**

## SIMPLE

- Only 3 moving parts!
- Little maintenance and nothing to adjust!
- Hoses stay between excavator links.

## SAFE

- Cannot release even in the event of full hydraulic failure.
- Fully Compliant with ISO standard 13031.
- Unique front and rear hooks guarantee 100% pin coverage.
- Compatible with audible indicators and other safety systems.
- Cannot be released in an unsafe position - see diagram on page 35.

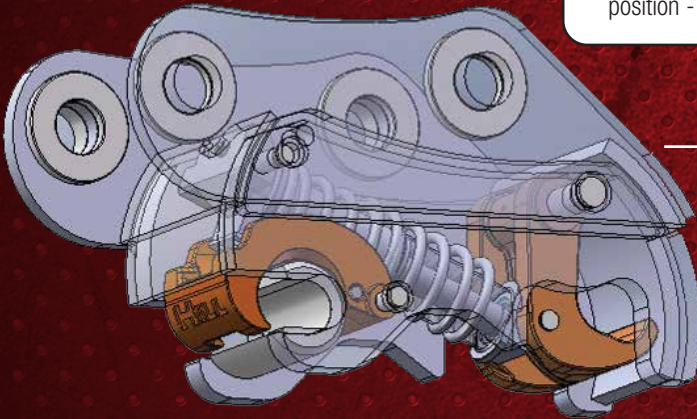

## VERSATILE

- Variable pin radius - one of the widest pick up ranges on the market!
- Will pick up most attachments within a given machine class.
- Accepts multiple pin sizes.



The patented smart valve is inside every HKR cylinder. It prevents release until the coupler is close to the excavator and fully curled. Because the valve is inside the cylinder, it is protected from any external damage.

# AWARD-WINNING DESIGN AND PATENTED FEATURES ARE WHY THE HKR IS IN DEMAND AROUND THE WORLD



## THE HKR DELIVERS...

- Unmatched safety.
- Fully compliant with ISO standard 13031.
- Fully automatic operation - never leave the cab!
- Variable pin radius - pick up multiple OEM attachments.
- Unmatched simplicity and reliability.
- Backed by Rockland's no-nonsense two year, 4,000 hour warranty.

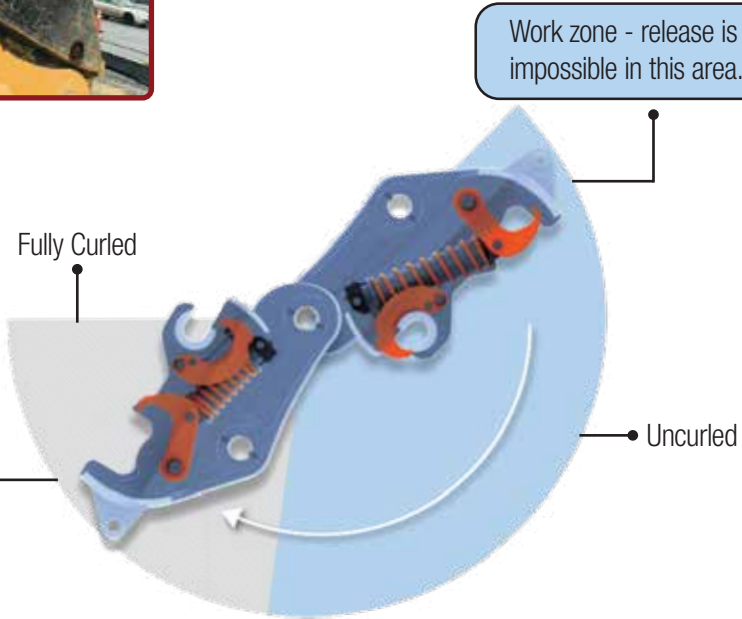

## HKRT Tilting Excavator Coupler

*All the benefits of the HKR coupler, plus tilt.*

- Tilt angle up to 180°.
- Self-lubricating actuator is essentially maintenance-free.
- Exceeds all current and expected global safety standards.
- Heavy-duty cast hooks provide full pin coverage.
- Coupler can only be released in safe position.
- Backed by Rockland's no-nonsense two year, 4,000 hour warranty.



# PACK SLOPES

## Up To 10 Times Faster



**CALVIN THOMPSON**, an experienced grading contractor, knew there had to be a better way to pack slopes. He'd spent years watching operators on crawler tractors waste time and money doing it the same old, slow, expensive way, so he invented the Thompson Slope Packer®.

His invention packs slopes more efficiently and at less cost than with a crawler tractor. The rest is profitable history.

Now you can pack slopes right up to the silt fence or other obstacles – and pack up to eight feet wide in a single pass. Expensive track wear is eliminated and labor costs are dramatically reduced.

### Thompson Slope Packer®

*Pack slopes up to 10 times faster.*

- Eliminate the high cost of packing slopes with a crawler tractor.
- Works on any grade.
- Pack soil right up to obstacles and silt fences without costly damage.
- Self-cleaning design. No need to wait for dry soil.
- 4', 6' and 8' widths for various excavator sizes.



**"This simple invention saved us big bucks."**

**– California Contractor**



# EXCAVATOR COMPACTION WHEELS

## Make Sense

**CONTRACTORS ACROSS NORTH AMERICA** count on Rockland Compaction Wheels. Their rugged, simple design compacts a variety of soils with maximum speed and efficiency. Spend your time working smarter and faster without the need for additional compaction equipment.



### Compaction Wheels

**Bolt-on outer rims equipped with Taperlocks make bearing replacement fast and easy.**

**Easy to reach grease fittings.**

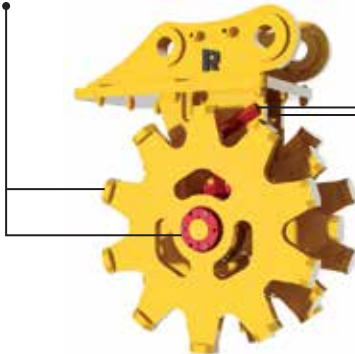

**TF TAMPERFOOT**

**Self cleaning design prevents soil buildup.**



**SF SHEEPSFOOT**

*Two designs depending on your compaction needs.*

- TF Tamperfoot: the ideal choice for most compaction needs.
- SF Sheepsfoot: Perfect for when mixing different soil types is needed.



**"My Rockland Compaction Wheel eliminated the need for an expensive compactor."**

**— North Dakota Contractor**



# LOADER EQUIPMENT



**Pg. 43**  
Coal Digging Bucket



**Pg. 43**  
Coal Loading Bucket



**Pg. 47**  
CS Cooling Slag Bucket



**Pg. 47**  
SD Slag Digging Bucket



**Pg. 47**  
SL Slag Loading Bucket



**Pg. 48**  
Aggregate Bucket

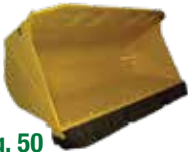

**Pg. 50**  
Trash Handling Bucket

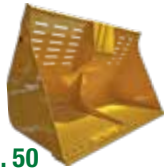

**Pg. 50**  
Transfer Station Bucket



**Pg. 51**  
Snow Basket



**Pg. 51**  
Snow Bucket



**Pg. 53**  
Ejector/Push Out Bucket



**Pg. 53**  
Rollout Bucket



**Pg. 54**  
Dual Cylinder Rollout Bucket



**Pg. 57**  
Rock Buckets



**Pg. 65**  
Rocklock® Loader Quick Coupler



**Pg. 67**  
Shaft-Mounted Bucket Forks



**Pg. 67**  
Car Body Fork



**Pg. 68**  
Heavy-Duty Construction Fork



**Pg. 71**  
LF Log Grapples



**Pg. 71**  
Dual Clamp Peeler Grapple



**Pg. 71**  
Wide Clamp Peeler Grapple



**Pg. 72**  
Millyard Grapple



**Pg. 73**  
Tree Length Log Grapple



**Pg. 74**  
Cleanup Grapple



**Pg. 74**  
Brush Handling Grapple



**Pg. 75**  
Tire Grapple



**Pg. 43**  
Light Material Bucket

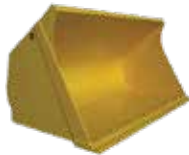

**Pg. 44**  
GPH Material Handling Bucket



**Pg. 44**  
GPX General Purpose Excavation Bucket



**Pg. 46**  
MHS Molten Slag Bucket



**Pg. 49**  
Demolition Bucket



**Pg. 49**  
Multi-Purpose Bucket



**Pg. 49**  
Side Dump Bucket

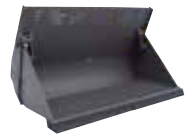

**Pg. 50**  
Multi-Purpose Trash Handling Bucket



**Pg. 51**  
Snow Pusher



**Pg. 52**  
SO Slip-On Bucket



**Pg. 52**  
SOHD Slip-On High Dump Bucket



**Pg. 52**  
Woodchip Bucket



**Pg. 57**  
Rock Tine Bucket



**Pg. 58**  
Super-Duty Quarry Bucket



**Pg. 64**  
General Purpose Clamp Bucket



**Pg. 64**  
Light Material Clamp Bucket



**Pg. 68**  
Utility Construction Fork



**Pg. 69**  
Log Fork



**Pg. 69**  
Pallet Fork



**Pg. 69**  
Rock Fork



**Pg. 72**  
East Coast High-Capacity Millyard Grapple



**Pg. 72**  
West Coast High-Capacity Millyard Grapple



**Pg. 73**  
Sorting Grapple



**Pg. 73**  
General Purpose Sorting Grapple



**Pg. 75**  
Pipe Grapples



**Pg. 77**  
Loader Rake



**Pg. 77**  
Loader Rake With Clamps



# ROCKLAND LOADER BUCKETS

Help You Get The Job Done Right



**CONTRACTORS HAVE TRUSTED ROCKLAND** since we began designing and manufacturing specialty loader buckets in the early 1950s. That's a lot of satisfied customers and over 65 years of hard-won, real-world experience. If you are not satisfied with the performance or quality of OEM buckets, you can depend on Rockland.

Every Rockland bucket is built to perform and last. Proven designs, high-quality wear packages, and world-class welding deliver maximum productivity and stand the test of time. All of our buckets are built out of maximum-strength, weight-saving alloy steel for maximum payloads and long life.

**"There's no bucket quite like a Rockland Bucket.  
If you want quality, get a Rockland. No questions asked."**

**— South Dakota Contractor**





# HOW IS LOADER BUCKET CAPACITY CALCULATED?

**Rated loader bucket capacity is calculated by adding the struck capacity to the material heap of the bucket. The material heap is calculated based on an ISO Standard. The total of these two calculations is the rated capacity of the bucket. The rated capacity can be further refined by application, by considering a material “fill factor”, in order to determine how much material will be moved per pass. More details below.**

**Struck Capacity:** Calculated by filling the bucket and then “leveling off” the material across the top. The volume of the remaining material is the struck capacity (shown in red on the diagram). It is typically measured in cubic yards and/or cubic meters. This volume is then added to the heaped volume below.

**Material Heap:** The “heap” of the material is added to the top of the bucket using a 2:1 ratio, or approximately a 27 degree angle on all sides of the bucket (shown in blue). This volume is also measured in cubic yards and/or cubic meters.

**Rated Capacity: Struck Capacity + Material Heap.** The sum of the struck capacity and material heap capacity above. The rated capacity of a bucket is its published capacity.

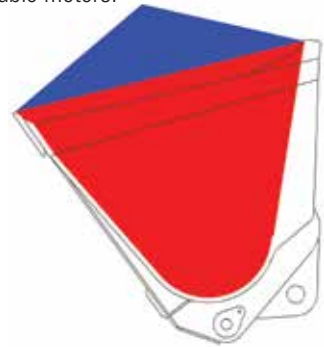

## SO WHAT IS “FILL FACTOR” AND WHY IS IT IMPORTANT?

Fill factor is where reality starts to meet the straight math of calculating rated capacity. Because all materials load differently, the calculated heap can be greater or smaller than the actual heap. For example, wet sand can clump in large amounts beyond a normal material heap calculation, whereas fine gravel does not pile as high. An extreme example would be handling liquid. Liquid would simply just fill up the bucket - giving it a fill factor of 0%!

In addition to the material and the moisture level, other criteria can affect fill factors. Factors including but not limited to: bucket rack back angle, bucket profile, operator skill, material profile/shape, and wear parts like teeth or bolt-on cutting edges also play a role.

To the right are some typical fill factors for common materials for quick reference.

MATERIAL DESCRIPTION	FILL FACTOR*
<b>Loose Material</b>	
Mixed Moist Aggregates	95-100%
Uniform Aggregates up to 1/8" (3mm)	95-100%
1/8"-3/8" (3mm-9mm)	90-95%
1/2"-3/4" (12mm-20mm)	85-90%
1" and over (24mm+)	85-90%
<b>Blasted Rock</b>	
Well Blasted	80-95%
Average Blasted	75-90%
Poorly Blasted	75-90%
<b>Other</b>	
Rock Dirt Mixtures	100%+
Moist Loam	100%+
Soil, Boulders, Roots	80-100%
Cemented Materials	85-95%

\* Reference Only. For specific fill factors by application, CALL US!



# KNOW WHICH BUCKET WORKS BEST!

GPH Material Handling Bucket	Ideal for handling, stockpiling, and loading of processed materials such as crushed stone, sand, gravel, and aggregate. Flat floor helps maintain a clean and level work area. Suitable for low impact and moderate abrasion. Additional wear protection can be added for high abrasion applications.
GPX General Purpose Bucket	The best “all-around” bucket. Well suited for handling loose material and aggregates when equipped with bolt-on edge. When equipped with teeth it works well for digging applications such as loose overburden or stripping topsoil and can be used occasionally for loading easily broken material from banks. Suitable for moderate abrasion and moderate impact.
HDV / HDS Rock Bucket	Optimized for loading well shot rock and ore, or easily broken materials during bank loading. Can also be used for occasional face loading. High breakout capability and well suited for moderate abrasion and high impact.
SDQ Super Duty Quarry Bucket	Recommended for extreme digging applications such as face or bank loading in mines and quarries. Intended for applications where high abrasion and high impact is encountered frequently. Ideal for applications such as iron ore and granite.

Bucket Features	GPH Material Handling Bucket	GPX General Purpose Excavation Bucket	HDV (Spade Edge) or HDS (Straight Edge) Rock Bucket	SDQ Super Duty Quarry Bucket
Flat floor design	<i>Standard</i>			
Fully constructed from wear resistant material			<i>Standard</i>	<i>Standard</i>
Spade nose design		<i>Optional</i>	<i>Optional</i>	<i>Standard</i>
Bolt-on edges	<i>Standard</i>	<i>Standard</i>	<i>Optional</i>	<i>Optional</i>
Teeth		<i>Optional</i>	<i>Standard</i>	<i>Standard</i>
Wear caps		<i>Optional</i>	<i>Optional</i>	<i>Standard</i>
Segments		<i>Optional</i>	<i>Optional</i>	<i>Standard</i>
Top covers				<i>Standard</i>
Vertical wear shrouds	<i>Optional</i>	<i>Optional</i>	<i>Optional</i>	<i>Standard</i>
Bolt-on edge on rear of cutting edge				<i>Standard</i>
Weld-on skid shoes	<i>Optional</i>		<i>Optional</i>	
Bolt-on skid shoes		<i>Standard</i>	<i>Standard</i>	<i>Standard</i>
Weld-on foundation wear plates	<i>Standard</i>			<i>Standard</i>
Shell liner		<i>Optional</i>	<i>Optional</i>	<i>Standard</i>
Rock deflectors			<i>Optional</i>	<i>Standard</i>
Upper outside endplate liners				<i>Standard</i>
Lower outside endplate liners	<i>Optional</i>	<i>Optional</i>	<i>Standard</i>	<i>Standard</i>
Inside endplate liners				<i>Standard</i>
Corner wear strips				<i>Standard</i>
Base edge end protectors				<i>Optional</i>
Cast corner wear shoes				<i>Optional</i>
Two additional vertical wear shrouds				<i>Optional</i>
Mechanically attached wear plates				<i>Optional</i>
Hardfacing	<i>Optional</i>	<i>Optional</i>	<i>Optional</i>	<i>Optional</i>

## Coal Digging Bucket

*The best choice for digging and loading coal!*

- Coal slides in and rolls up in one easy, smooth-filling motion.
- Long, flat bucket bottom and flush-mount teeth produce a flat quarry floor.
- Reinforced bucket floor stands up to years of applied machine breakout force when digging out coal.
- Visibility slots allow the operator to see the cutting edge when approaching the pile.
- Equipped with bolt-on edges, teeth, and wear parts of your choice.



## Coal Loading Bucket

*Increase coal-loading capacity by up to 50%!*

- Specifically designed for your machine with the type of coal being handled in mind. This delivers maximum cubic yards moved per pass, greatly increasing loader production on every shift.
- Slope bottom reduces wear and extends bucket life.
- Lightweight design increases available bucket capacity.
- Equipped with reversible bolt-on cutting edges and other wear parts of your choice.



## Light Material Bucket

*Maximize your machine's capabilities on every pass!*

- Perfect for mulch, wood chips, dry topsoil, fertilizer, and livestock feed applications.
- Move as much as your machine can handle, every time.
- Slope-bottom design and replaceable wear plates extend bucket life.
- Lightweight, high-strength alloy steel construction delivers years of dependable performance.
- Equipped with reversible bolt-on cutting edges.



# GENERAL PURPOSE BUCKETS

## Help You Get ANY Job Done Right

### GPH Material Handling Bucket

*Flat bottom design produces a clean and level work area.*

- Perfect for stockpile work such as sand, gravel, & aggregate applications.
- Ideal for soft underfoot conditions.
- Standard full-length, replaceable wear strips on bucket bottom protect the bucket shell from wear.
- Equipped with reversible, bolt-on cutting edges.
- Custom wear parts, visibility slots, hardfacing, and other features available upon request.



### GPX General Purpose Excavation Bucket

*Great for loading and stockpiling medium to heavy weight materials.*

- Excellent all-around bucket for many application types.
- Sloped bottom design maximizes machine breakout force.
- Straight, spade, and modified spade edge configurations available.
- Available with teeth, hardfacing, segments, shrouds, liners, and other options on request and/or based on application.
- Equipped with bolt-on skid shoes as well as weld-on skid shoes available.
- Equipped with reversible, bolt-on cutting edges.



# GENERAL PURPOSE BUCKET COMPONENTS & TERMINOLOGY



**GPX General Purpose  
Excavation Bucket**



**GPH Material  
Handling Bucket**



# SLAG BUCKETS BUILT TO HANDLE HIGH HEAT & ABRASION



## **MHS Molten Hot Slag Bucket**

### *The ultimate bucket for handling molten slag.*

- Built specifically for handling molten slag at 1200° F and above.
- Custom bucket foundations are built to withstand thermal expansion.
- Extra-thick end plates absorb heat and eliminate distortion.
- Thick shell adds strength from cutting edge to spillguard.
- Sloped-bottom design and replaceable skid pads reduce bottom wear.
- Available in straight, spade, or modified spade edge configurations.
- Equipped with your choice of points and adapters.
- Segments, bolt-on cutting edges, carbide hardfaced edges, hardfacing, and wear shrouds available upon request and application.



## CS Cooling Slag Bucket

*Break up cooling slag from slag pot operations & processors.*

- Effectively breaks through layers of cooled slag & able to withstand increased temperatures of the buried slag. Typically used in applications below 1200° F.
- Available in straight, spade, or modified spade edge configurations.
- Reinforced foundation delivers maximum breakout power while preventing bucket failure and lip cracking.
- Optional liners, shrouds, and segments protect the bucket shell and base edges, reducing rebuilding costs and prolonging bucket life.
- Equipped with your choice of teeth or optional, reversible, bolt-on cutting edges.
- Weld-on edges, shrouds, hardfacing, liners, and more options available up request.



## SD Slag Digging Bucket

*Dig and load cold, hard slag.*

- Spade nose design provides excellent pile penetration.
- Designed to withstand the abuse of handling sharp and abrasive slag deposits.
- Full-length foundations increase bottom strength.
- Slope-bottom design for easy loading.
- Available with points and adapters of your choice.
- Available with hardfacing, shrouds, segments, and many other options based on your applications specific needs.



## SL Slag Loading Bucket

*Designed to stand up to the constant abrasion of loading processed slag.*

- Full-length, replaceable wear strips deliver long life and dependable performance.
- Straight sidecutters improve pile penetration on every pass.
- Equipped with reversible, bolt-on cutting edges standard.
- Available with points and adapters of your choice.
- Available in straight or spade edge configuration.
- Hardfacing, shrouds, segments, and other custom wear options are available upon request.



# ROCKLAND AGGREGATE BUCKETS

Work Smarter, Not Harder



## Aggregate Bucket

*Designed specifically for handling sand, gravel, & crushed stone!*

- Longer floor & rounded sidecutters provide maximum material retention.
- Center spillguard protects machine linkage.
- Sized for your application and machine! Move more material per pass than the standard bucket.
- Equipped with bolt-on skid shoes. Weld-on skid shoes available at no extra charge.
- Available with a sloped or flat bottom design.
- Available with straight or spade edges, liners, shrouds, and additional wear parts on request.



## Demolition Bucket

*The ultimate choice for tough demolition work!*

- Increase productivity – dig, load, doze, and grab all with one tool!
- Fully enclosed, heavy-duty Rockland cylinders deliver years of dependable service.
- Available with bolt-on edges or teeth.
- Custom wear parts, capacities, clamp designs, and other items available upon request.



## MP Multi-Purpose | 4 in 1 Bucket

*A loader bucket, clam, dozer blade, box scraper, and bottom dump bucket in one attachment!*

- Avoid downtime, warped clamps, failed cylinders, and hassle by choosing a Rockland heavy-duty multi-purpose bucket.
- Clam bottom reinforced with high-strength steel wear strips.
- Rugged moldboard equipped with top and bottom flange plates deliver dozing strength.
- Heavy-duty Rockland hydraulic cylinders provide years of dependable service.
- Equipped with your choice of teeth or reversible, bolt-on cutting edges.
- Available for pin-on and coupler applications.



## Side Dump Bucket

*Easily load and unload in confined areas.*

- Ideal for applications such as highway construction sites, trenches, roadways, and tunnel construction.
- Reduce excess loader travel and lost time by simply pulling beside the truck or trench to dump sideways.
- Dual-cushioned, Rockland built cylinders provide safe, smooth, and quiet operation.
- Hydraulic lock prevents the bucket from moving when dump cylinder is not engaged.
- Center-mounted lift hook is standard.
- Left-hand dump is standard. Right-hand dump is available upon request.



## MPL Multi-Purpose Trash Handling Bucket

*If you're using a standard bucket for trash, you're working too hard.*

- Crush, pick, sort, & doze with one versatile tool. No need to switch attachments!
- Heavy-duty clamp, oversize pivots, and wear strips prolong bucket life.
- Equipped with a heavy-duty, slotted spillguard for increased visibility.
- Equipped with bolt-on cutting edges and replaceable end bits.
- Available with wear parts, rubber cutting edges, and other options.



## Trash Handling Bucket

*Load more trash on every pass.*

- Replaceable, over-sized cheek plates and thick, lower corner blocks protect against damage from rubbing transfer station walls.
- Clipped corners increase visibility and prevent hang-ups on truck beds, building columns, metal siding, walls, and floors.
- High-strength, alloy steel design extends bucket life while adding capacity and reducing bucket weight.
- Easily replaceable, bolt-on skid shoes reduce bottom wear.
- Equipped with reversible, bolt-on steel cutting edges or rubber edges of your choice.
- Additional trash guards, wear parts, liners, and other options available upon request.



## Transfer Station Bucket

*Load, doze, and pile efficiently.*

- Quickly push and pile large loads with ease.
- Tall profile dramatically increases dozing capacity while keeping trash in the bucket.
- Short bucket bottom increases dump height, allowing you to load easier and faster.
- Slotted spillguard delivers maximum machine protection and increased visibility.
- Equipped with reversible, bolt-on steel cutting edges or rubber edges of your choice.

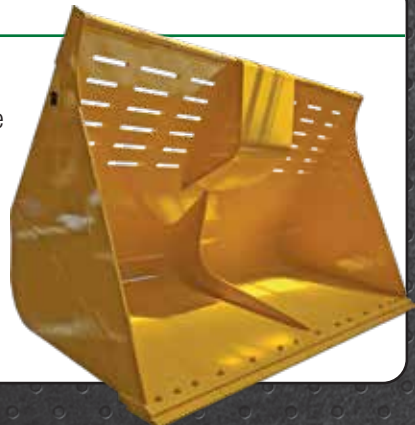

## Snow Basket

### *Move more snow!*

- Greatly increase the capacity of your loader with the unique weight saving design!
- Slotted design allows air to pass through when pushing large mounds of snow – decreasing bucket weight, increasing the amount moved per pass, and reducing the amount of snow that sticks in the bucket.
- Water from slushy, water-logged snow is not trapped in bucket. Move what you need, leave what you don't.
- Equipped with reversible, bolt-on cutting edges standard.



## Snow Bucket

### *Ideal for tough snow-loading jobs.*

- Dig old piles of snow with heavy concentrations of ice.
- Lightweight design maximizes capacity and delivers years of dependable performance.
- Sloped bottom design with easily replaceable bolt-on skid shoes reduces bottom wear.
- Equipped with reversible, bolt-on cutting edges standard.
- Additional custom options available upon request.

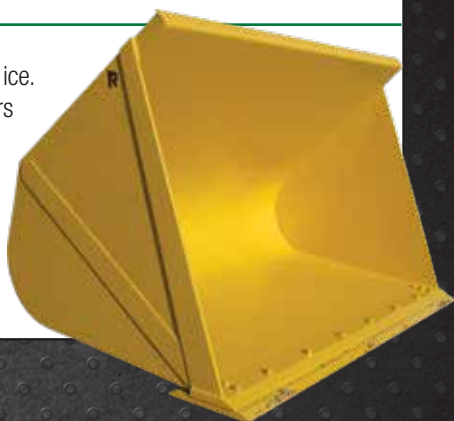

## Snow Pusher

### *Get the most out of your loader this winter!*

- Easily installs onto existing bucket with chain binder.
- Many width and capacity options available. Push more snow per pass, every time!
- Replaceable, bolt-on skid shoes on wings.
- Available with rubber edges as standard, steel edges upon request.
- Available in pin-on or coupler applications upon request.



## SO Slip-On Bucket

*Quickly convert forks to a bucket without using a coupler.*

- Quickly connects to your log grapple.
- The perfect solution for occasional sawdust or woodchip loading.
- Equipped with reversible, bolt-on cutting edges and replaceable wear plates.



## SOHD Slip-On High Dump Bucket

*Achieve greater heights with your loader.*

- Quickly connects to your log grapple, eliminating the need for loading ramps or boom arm extensions.
- Dump at heights as high as 13'6".
- Easily dumps from the tine tips by simply opening the clamp!
- Equipped with reversible bolt-on cutting edges.
- A simple, innovative solution for today's forward thinking log and chip handling operations.

Shown with Rockland LF-W Log Grapple.



## Woodchip Bucket

*Load more woodchips every time.*

- Bucket capacity optimized for the weight of your chips, wet, dry, or both - delivering maximum material moved per pass.
- Heavy-duty, slotted spillguard provides excellent material retention and operator visibility.
- Reinforced at critical stress areas to withstand the day to day operations of a chip mill.
- Equipped with reversible, bolt-on cutting edges.



## Ejector / Push Out Bucket

### *Push material out!*

- Ideal for wet and sticky materials or overcoming dump height clearance issues in tight spaces.
- Increase dump height by over 3' compared to a standard bucket.
- Easily meter loads to reduce spillage and eliminate waste.
- Hydraulic push-plate powered by two heavy-duty Rockland cylinders guarantee the entire load is dumped every time.
- Rubber skirting keeps bucket clean after every dump – no material buildup!
- Equipped with reversible, bolt-on cutting edges. Rubber bolt-on edges also available.



## RL Single Cylinder Rollout Bucket

*Get the dump height you need at a fraction of the cost.*

*Why spend money on a bigger loader?*

- Easily load high-sided trucks, trailers, hoppers, & tub grinders.
- Dump up to 3' over your machines hinge pin height.
- Rockland designed and built cushioned center-mounted cylinder delivers years of dependable service.
- Equipped with reversible, bolt-on cutting edge.
- Additional options, wear parts, and guarding upon request.
- For use in coupler and pin-on applications.



Check out our  
**RL2 Dual Cylinder  
 Rollout Bucket** on  
 pages 56-57.



## RL2 Dual Cylinder Rollout Bucket

### *The rollout bucket that does it all!*

- Easily load high-sided trucks, trailers, hoppers, & tub grinders.
- Dump up to 3' over your machines hinge pin height.
- The open floor makes loading easier and reduces material buildup.
- Sloped-cylinder pockets prevents material from sticking in the bucket.
- Fully-enclosed hydraulics prevent hose wear and unexpected snags.
- Faster and safer maintenance – grease the entire bucket without rolling the bucket out of the carriage – a Rockland exclusive!
- Cushioned, Rockland cylinders deliver years of dependable performance and roll-out power.
- Cylinder pockets, foundations, and bucket carriage design keep the center of gravity as close to the machine as possible resulting in better stability and more material per pass!
- Equipped with reversible, bolt-on cutting edges.
- Available with custom wear parts, visibility slots, spillguards, and other options upon request.





**Curved sidecutter design reduces material spillage.**

**Custom bucket profile increases loader stability and maximizes carry capacity.**

**Recessed pin heads eliminate potential damage and keeps your bucket working.**

**Fully enclosed hydraulics eliminate damaged lines and hydraulic spills.**



**High visibility slots. Available in many configurations based on the size of the material being handled.**

**Sloped cylinder pockets & recessed pins reduce material buildup. That means more material moved on every pass.**

**Open Floor Design. Efficient Material Loading and Unloading.**

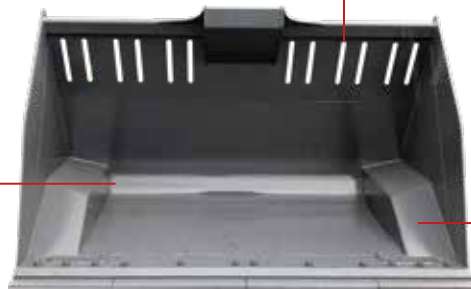

**Fully external grease points. Saves time and makes maintenance easy.**

**Fully enclosed hydraulics eliminate damaged lines and hydraulic spills.**



# ROCK AND QUARRY BUCKETS





## HD-V and HD-S Rock Buckets

*Built to last in the toughest quarries.*

- Built exclusively for work in quarry and rock handling applications where abrasion is constant.
- Straight sidecutters and bucket profile deliver improved penetration.
- Sloped-bottom reduces bottom and corner wear, extending bucket life.
- Bolt-on, replaceable skid shoes preserve bucket bottom and eliminate expensive rebuilds.
- Available with points and adapters of your choice.
- Available with a host of options, including but not limited to: scalloped/custom profile end plates, reversible bolt-on cutting edges, half-arrow edges, wear shrouds, hardfacing, liners, segments, visibility slots, spillguards, rock deflectors, and wear buttons.
- Available in straight edge or spade nose configuration.
- The serious choice for a serious application. Rockland rock buckets are covered by Rockland's **industry exclusive** lifetime warranty against failure due to defective design, material and workmanship.

**History Fact!** Rockland was the **first** allied equipment manufacturer to build a wheel loader rock bucket!



**HD-V Spade Nose**  
with bolt-on edges



**HD-S Straight Edge**  
with teeth and segments



## Rock Tine Bucket

*Sort and sift like a pro!*

- Load only what you need and leave what you don't.
- Eliminate the cost of bringing in extra free base material – use what you already have!
- Variable tine spacing for your application.
- Equipped with reversible bolt-on cutting edges or your choice of points and adapters.
- Additional wear plates and options available upon request.



# SDQ SUPER DUTY QUARRY BUCKET



## SDQ Super Duty Quarry Bucket

*Designed for extreme severe service shot-rock applications.*

- Two-piece end plate liners, inside and out, protect the bucket sides.
- Three-piece shell liner protects the bucket core eliminating the need for complete rebuilds.
- Optional patented wear-pin liners show how much and where the wear is occurring so replacement parts are ready before they are needed, and maintenance happens on schedule!
- Built-in rock deflectors push material away from the loader tires.
- Fully reinforced and protected sloped bucket bottom with skid shoes for extended life.
- Heavy-duty, built-in spillguard with visibility slots increase safety.
- Available in straight, spade, or modified spade edge configuration.
- Equipped with your choice of teeth and segments.
- Available with a host of options, including but not limited to: scalloped/custom profile. end plates, half-arrow edges, wear shrouds, hardfacing, segments, and wear buttons.
- Rockland rock buckets are covered by Rockland's **industry exclusive** lifetime warranty against failure due to defective design, material and workmanship.



# SUPER DUTY QUARRY BUCKETS

Help You Get the Job Done Right

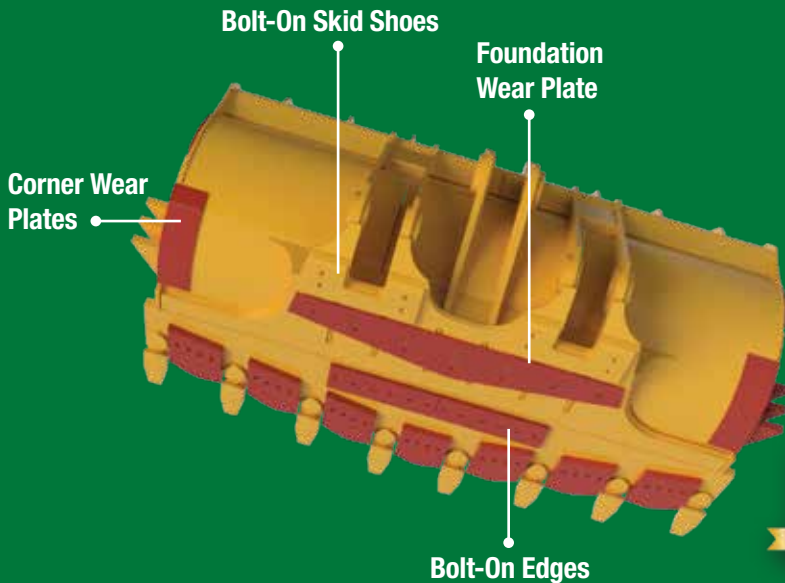
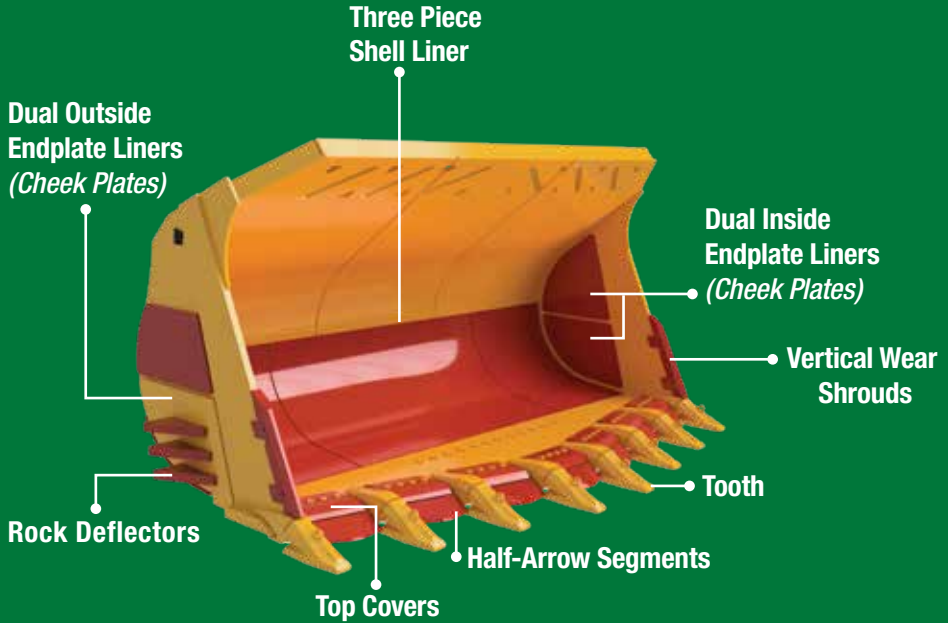

Made in the USA 61

# OPTIONS MAKE ALL THE DIFFERENCE



**EXPERIENCED OPERATORS SAVE MONEY** because they know the right options greatly improve bucket performance and reduce downtime and maintenance cost. The most commonly specified Rockland bucket options, and when to use them, are listed to the right. Give yourself an advantage on every pass by designing a unique bucket for ***your*** job.

## **Vertical Wear Shrouds**

*Protect the bucket sidecutters from excessive wear. Available as weld-in inserts made from 500 brinell hardness steel or as pin-on castings available in a variety of shapes and styles.*



### Hardfacing

*Extremely abrasion resistant material applied via a welding process. Hardfacing is available in many hardnesses, can be reinforced with carbide chips, and be applied virtually anywhere it's needed. Specific patterns of hardfacing, when taking into account material flow, further extend wear life.*



### Liners

*Protect the bucket shell from wear and prevent expensive rebuilds. Available in full flush-mount three-piece set ups, full and 1/2 liners. Liners are easily replaced and are available in many steel types, including high wear composite steels. Patented wear pins are also available.*



### Cheek Plates

*Protect the bucket end plates from wear. Weld-on inside and outside end plate doublers can be easily replaced, preventing end plate rebuilds. Available in many types of steel, based on application.*



### Rock Deflectors

*Push away rocks and help prevent tire damage. Heavy-duty wings welded to the bottom of the end plates continually push rocks away from valuable tires!*



### Skid Shoes

*Protect the bottom of the bucket. Available as weld-on or bolt-on, can be equipped with hardfacing, and made out of many different grades of steel based on the needs based on the application.*

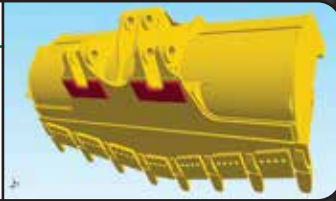

### Visual Wear Pins

*Wear pins appear when liner or moldboard has worn 50%. See next page!*

*Canadian Patent 10,378,188*



### Extended Spillguard

*Standard on all Rockland buckets. In high-capacity applications, an extended spillguard helps protect loader arms and dump linkage. Available with visibility slots and/or heavy-duty woven wire windows.*



# VISUAL MAINTENANCE FOR BUCKETS & BLADES

## **PATENTED** WEAR PIN TECHNOLOGY



- **Proactively schedule maintenance to eliminate unnecessary downtime.**
- **Wear Pins appear when liner or moldboard has worn 50%.**
- **Easily test different wear materials in your application.**
- **Available in most loader bucket shells and dozer blades!**



# CLAMP BUCKETS

## Make Quick Work of Bulky Materials



**SECURELY LOAD HARD-TO-HANDLE MATERIAL** Perfect for materials that don't quite fit, or easily stay in a standard bucket. Sized right to maximize productivity and built tough to stay working longer!

### GPC General Purpose Bucket With Clamps

*Handle difficult loads with ease.*

- Rugged, dual clamps to handle large bulky materials.
- Heavy-duty, Rockland built, cushioned cylinders deliver years of dependability.
- Built-in mechanical stops prevent cylinder damage.
- Ideally suited for materials over 1,500 lbs./cu. yd.
- Clamp widths proportional to bucket widths – linked clamps also available.
- Clamps open behind cutting edge to protect cylinders.
- Equipped with reversible bolt-on cutting edges.
- Additional options, rubber cutting edges, and more available upon request.
- No-nonsense two year, 4,000 hour warranty.



### LBC Light Material Bucket With Clamps

*Boost productivity when handling light, bulky material.*

- Lighter duty bucket means more capacity for light-weight materials.
- Rockland built, cushioned cylinders, deliver years of dependability.
- Built-in mechanical stops prevent cylinder damage.
- Clamp widths proportional to bucket widths – linked clamps also available.
- Clamps open behind cutting edge to protect cylinders.
- Equipped with reversible, bolt-on cutting edges.
- Additional options, rubber cutting edges, and more available upon request.





# ROCKLOCK® COUPLER

Turn Your Loader Into A Multi-Purpose Machine



**TAKE IT TO THE NEXT LEVEL.** Your loader will make you more money with a Rocklock® coupler because it will become a tool for many more jobs. Rocklock® couplers can be built to accept nearly any coupler interface on the market so that you can use all the attachments you already own. Rocklock® couplers are available in a heavy-duty version that stands up to extreme applications.

- Increase the versatility of any loader.*
- Quickly change attachments.
  - Increase safety by staying in the cab.
  - Available to work with many types of current coupler systems.
  - Comes ready to work, easy to install. Multiple install options are available to suit any machine configuration.
  - Heavy-duty version available for extreme applications.
  - No-nonsense two year, 4,000 hour warranty.



“The Rocklock® coupler system gives me the ability to change between quality Rockland attachments with lightning speed.”

– Washington D.C. Contractor

# ROCKLAND FORKS

Deliver Dependability and Productivity Every Day.



## SPECIFY ROCKLAND AND GET THE RIGHT FORK FOR YOUR JOB.

Rockland forks are built for the application. There are numerous tine options, backframe styles, and fork widths to choose from. Machines equipped correctly for the job add value day after day and eliminate unnecessary handling steps, wasted time moving tines to the right locations, and deliver years of break-down free service. More information about our most common fork models can be found on pages 69 through 71.

"My Rockland Forks give me the ability to load stuff  
you can't get in a bucket."

— Mississippi Contractor



## Shaft-Mounted Bucket Forks

*The most convenient and cost-effective way to give your loader the ability to do more every day.*

- Handle pallets and other small loads without removing the bucket.
- Adjustable high-quality, forged tines, sized for the machine, deliver years of dependable service.
- Mounting brackets and high-strength hanger bar always included.
- Easily shared on multiple buckets or amongst multiple machines by adding extra mounting brackets.
- In stock and ready for quick delivery.



## Car Body Fork

*Tougher than a junkyard dog.*

- Auto salvage yards increase productivity when using car body forks. Handling cars in volume and reducing damage of critical components is key to increasing scrap yard profits.
- High-strength, fixed tines can withstand all of the machine's power.
- Tines equipped with bottom or top taper, full or partial, as requested. This makes getting under cars and unloading trucks fast and easy.
- Optional frame heights and widths available to suit applications that vary as widely as handling one car, or many, in one pass.
- Tine lengths from 6 to 14 feet make it easy for operators to reach what they are after.
- Optional rubber bumpers protect valuable parts from damage.
- Custom backframe with clamps for securing tall loads available upon request.



# ROCKLAND FORKS

## The Solution For Greater Productivity

### CFHD Heavy-Duty Construction Fork

*The ultimate fork for heavy use and heavy loads.*

- Built to withstand anything your machine can do. All CFHD forks are equipped with breakout force rated tines. Perfect for demanding applications ranging from oil field work to heavy lifting applications.
- Heavy-duty tine shafts and fully welded tine bosses deliver years of dependable performance.
- Tines always stay close to the frame, even when dumping. This prevents operator error and improves safety.
- Simple and fast tine adjustment means more loading and less struggling with hard to move tines.
- Multiple tine lengths and frame widths available to suit any application.



### UCF Utility Construction Fork

*The most versatile and cost-effective utility fork available.*

- High quality, load rated, forged tines deliver years of dependable service.
- Clearly marked with tine load rating – know how much can be lifted all the time.
- Multiple tine lengths and frame widths available to suit any application.
- Simple and fast tine adjustment means more loading and less struggling with hard to move tines.
- Tines don't swing away from frame, even when dumping. This prevents operator error and improves safety.
- No-nonsense two year, 4,000 hour warranty.



## LF Log Fork

*The right fork for tough log yard work.*

- Low-profile backframe maximizes visibility.
- Heavy-duty, breakout force rated tines and the reinforced backframe handle the rigors of log yard work with ease.
- Adjustable, floating tines compensate for uneven ground, increasing productivity.
- Tine float can be locked out if desired.
- Multiple tine lengths and frame widths available to suit any application.

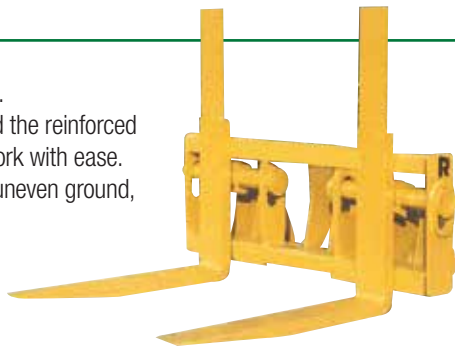

## PLF Pallet Fork

*A cost-effective alternative to a dedicated forklift.*

- Open backframe increases visibility for easy pickup and placement.
- Multiple tine lengths and frame widths available to suit any application.
- Equipped with high quality, industry standard ITA style tines. Heat-treated & fully adjustable.
- Rockland quality backframe ensures years of dependable performance.
- A far cry from cheap, imported pallet forks. A serious tool for a serious job.



## Rock Fork

*Built for tough rock handling applications.*

- Severe duty frame delivers long life in the quarry.
- Oversized, fixed tines withstand any quarry rock your machine can handle.
- Multiple tine lengths and frame widths available to suit any application.
- Manufactured with high-strength, heat-treated alloy steel.
- Available with full and partial tine tapers, top and bottom, upon request.
- Custom logos, wear parts, and clamps available upon request.

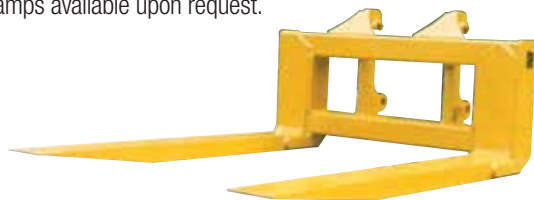

# ROCKLAND LOADER GRAPPLES

Designed To Perform And Built To Last



**ROCKLAND LOADER GRAPPLES** let your loader do more. From sugar cane to logs, to rock, pipe, tires, and more, Rockland grapples have been helping operators get the job done reliably and efficiently for over 65 years all over the world. Rockland grapples keep the load size right and the center of gravity close to the machine to keep production high. These features combined with weight-saving designs and heavy-duty Rockland built cylinders deliver productive, efficient shifts day after day. You can learn more about our most common grapple models on pages 73 through 79.

"We specify Rockland Grapples because they are built to last."

— West Virginia Contractor



## LF Log Grapples

*The right choice for standard log handling applications.*

*Three different models for each application.*

- The LF-1 features a single, center clamp for shorter logs and minimum grapple weight.
- The LF-2 dual clamps are perfect for handling unusually shaped or uneven loads.
- The LF-W wide clamp, our most popular log grapple, stabilizes both long and short logs on every pass.
- **All LF log grapples are equipped with:**
  - Multiple tine lengths and frame widths available to suit any application.
  - High-strength, breakout-force rated tines to deliver years of dependable service.
  - Floating tines standard on all models.
  - Easy tine width adjustment keeps operators loading more often.
  - Built-in float lockout available when floating tines aren't required.
  - Rockland heavy-duty designed and built cylinders deliver years of dependable performance.



**LFW Shown**



## Peeler Grapples

*The right choice for plywood and peeler applications.*

- Heavy-duty design stands the test of time in this very tough application.
- Narrow frame design for working between log bunkers and in conditioning vats.
- Equipped with hinged, easily replaceable tines.
- Dual-cushioned cylinders deliver years of dependable service.
- Available with dual clamps or wide clamp.
- No-nonsense two year, 4,000 hour warranty.

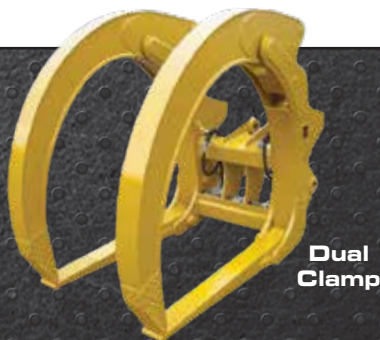

## Millyard Grapples

*The perfect choice for mill yard applications.*

- Efficiently handle large diameter, cut-to-length logs on every pass.
- Low-profile backframe gives operator maximum visibility while loading and unloading.
- Available with a wide clamp (MLW) and with dual clamps (ML2).
  - The MLW's wide clamp closes between the tines. Capable of handling both small and large loads.
  - The ML2's dual, independent clamps close on the tine tips and work best with uneven loads.
- Heavy-duty Rockland cylinders deliver years of dependable performance.
- Custom clamp profiles, wear parts, bolt-on yard levelers, pin-on tine tips, and more options are available.

**MLW Shown**



## High-Capacity Millyard Grapples

*Two Models - East Coast Style and West Coast Style.*

- Unload trucks in a single pass (most models).
- Powerful dual cylinders deliver high clamping force.
- Rounded clamp tips minimize log damage.
- T1 steel throughout, plus AR400 in all wear areas ensures long grapple life.

**East Coast**



**West Coast**





## SG Sorting Grapple

### *Unload trucks quickly and easily.*

- Perfect for feeding a mill, whether loading from stacks or reaching into bunkers.
- Large clamp area for medium and short timber delivers maximum productivity per pass.
- Wide clamp pivots on sealed, heat-treated, replaceable bushings for years of dependable service.
- Sized right with trailer stanchions in mind – for easy truck unloading.
- Heavy-duty, Rockland designed and built cylinders perform cycle after cycle.
- Available with built-in kicker clamp.
- Available with custom clamp profiles, wear parts, pin-on tips, and more upon request.



## SGG General Purpose Sorting Grapple

### *Sort and handle different types of timber quickly!*

- A great all-around grapple, ideal for all types of timber, including tree-length logs.
- Straighter clamp profile allows for better sorting and handling of single logs.
- Wide clamp pivots with sealed, replaceable bushings at all pivot points.
- Heavy-duty, Rockland designed and built cylinders deliver years of dependable service.
- Available with custom clamp profiles, wear parts, pin-on tips, and more upon request.



## Tree Length Log Grapple

### *The right tool for large diameter, tree-length logs.*

- Very wide frame handles long logs with ease!
- Deep “C” shaped backframe profile improves loading and unloading of large logs.
- Available with dual, independent clamps or single wide clamp.
- Heat-treated pins and replaceable bushings at all pivot points.
- Smart hose routing prevents hose snagging and damage.
- Heavy-duty, Rockland designed and built cylinders.
- Available with custom clamp profiles, wear parts, pin-on tips, and more upon request.



## Cleanup Grapple

*Grabbing and loading debris is easier than ever.*

- Perfect for fall cleanup in city environments and for picking up large loads of loose material.
- More efficient than a standard bucket eliminating wasted time hopelessly pushing debris around.
- Equipped with heavy-duty Rockland designed cylinders for years of dependable service.
- Available with screen extensions for handling even more light material per load.
- Reinforced clamp hinges, bottom plates, and replaceable cutting edges deliver years of dependable service.



## Brush Handling Grapple

*Increase productivity handling brush and large bulky loads, while leaving finer material behind.*

- Perfect for handling brush, logging debris, and any other light material in an application where you need to leave the dirt behind.
- Reinforced grapple teeth deliver years of digging and prying performance.
- Heavy-duty, cushioned Rockland cylinders provide unmatched gripping power.
- Optional tine widths, clamp spacing, and optional wear parts available upon request.



## Tire Grapple

*Save time avoiding struggling with loading tires and tire remnants.*

- Powerful top clamps and Rockland cylinders hold bulky loads in place with ease.
- Heat-treated pins and bushings, equipped with easy to reach grease fittings at every key pivot point maximize grapple life and your ROI.
- Available with custom tine spacing, clamp configurations, and capacities.



## PG Pipe Grapples

*The choice for pipe handling operation!*

- PG-1 grapples feature a single center stabilizer, ideal for layers or bundles of small and medium-size pipe.
- PG-2 grapple features dual, linked stabilizers that are ideal for handling larger, longer pipe.
- All Rockland pipe grapples are available with rubber coated clamp faces to minimize pipe damage.
- Heat-treated pins and bushings at all locations with easy to reach grease fittings make maintenance easy and reduces downtime.
- Powered by heavy-duty Rockland cylinders – for years of dependable performance.
- Available with custom clamps and in virtually any width.
- High-strength tines, sized specifically to withstand the power of your machine deliver dependable performance for years.



# ROCKLAND LOADER RAKES

Turn Your Loader Into An Efficient Land Clearing Machine



## CUT CLEARING COSTS - CLEAR AND LOAD WITH ONE MACHINE!

Rockland has been building loader rakes for over 50 years. Every Rockland loader rake features a tall, curved profile that delivers easy rolling, digging, and loading on every pass. Our LR loader rake series is the perfect low-cost, low-weight solution for effective wheel loader land clearing. The LRC Loader Rake has dual, independent clamps to get a firm grip on large, unbalanced loads. This greatly increases the amount of brush that can be moved per pass, while leaving the dirt behind!

"My Rockland LR Loader Rake cut my clearing costs over 50%."

— West Virginia Contractor



## LR Loader Rake

*Turn your wheel loader into an efficient land clearing machine.*

- Curved, high-strength alloy steel teeth dig, roll, stack, and load with ease.
- Rugged brush guard equipped with a center-mounted push bar allows you to trap and dig into tall trees more easily.
- Built entirely of light-weight, high-strength alloy steel that delivers excellent performance and maximizes the ability of the machine to carry as much as possible on every pass.
- Custom rake spacing, logos, wear parts, and other options are available upon request.



## LRC Loader Rake with Clamps

*For maximum landing cleaning on every pass!*

- Dual, independent clamps or optional wide clamp is designed to keep weight down while grabbing large and bulky loads with ease.
- A full-length, linked clamp can be added to provide positive load control and delivers even more material moved per pass in some applications.
- Utilizes the same proven, rough and tumble backframe design as the LR Loader Rake.
- Equipped with Rockland built, heavy-duty cushioned cylinders for years of dependable performance.
- Heat-treated bushings and grease fittings at all pivot points save time and make it easier to get proper maintenance completed.



**Wide Clamp  
Shown**



# DOZER EQUIPMENT



Pg. 79  
Dozer Slope Board



Pg. 79  
Multi-Shank Dozer Ripper

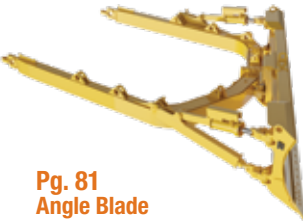

Pg. 81  
Angle Blade



Pg. 81  
Coal Blade



Pg. 81  
Semi U-Blade



Pg. 82  
Landfill Blade



Pg. 82  
Reclamation Blade



Pg. 82  
Woodchip Blade



Pg. 83  
SA-4 Shear Blade



Pg. 83  
VR Clearing Blade



Pg. 85  
RF-3 Severe Service Rake

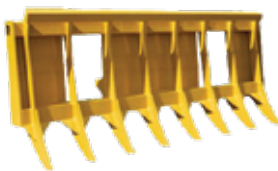

Pg. 85  
Multi-Application Rake



Pg. 85  
Blade Rake



Pg. 85  
SR Stacking Rake

## Dozer Slope Board

***Greatly increase your dozers clearing and grading ability!***

- Capable of fine grading, with the blade in any position, at an angle up to 82°!
- All grading adjustments are made from the cab - saving time, while enhancing and increasing productivity and safety.
- Full visibility of cutting edge minimizes errors and increases safety.
- Keep the dozer on level ground more often reducing dozer wear and maintenance.
- Optional blade extension, wear parts, logos, and other customizations available.
- Available in dual and single blade set ups.



**Inside Mount**



**Outside Mount**

## Multi-Shank Dozer Ripper

***Rip rock, soil, and frozen ground with ease!***

- Your choice of 3 or 5 shanks.
- Parallelogram or variable pitch designs available.
- Rapid ground penetration and aggressive ripping angle at any depth!
- Replaceable hardened bushings and shank pockets ensure years of trouble-free operation.
- Choose from multiple shank options or use your own!



# DOZER BLADES

## Designed For Your Application



**ROCKLAND DOZER BLADES** doze material on five continents. Rockland blades have built their reputation by delivering performance for over 65 years, and are preferred by large OEMs and operations around the world. They are correctly matched to the machine and material to deliver maximum dozing productivity and an even rolling load. They feature high-strength, alloy steel box frame construction with heavy-duty brackets and heat-treated cutting edges. Rockland blades are available in many models, for many applications and can be customized for each and every application.

"We equip all our dozers with Rockland Blades - ever since they proved to us that they go the extra mile to stand behind their products."

— Kentucky Coal Mine Owner





## Angle Blade, C-frame, and Brace Group

*The ideal choice for tough land clearing, pipeline pioneering, and road building applications.*

- Available with many options based on the specific application or the region of use.
- Complete C-frame, angle blade and brace group arrives ready to install on your OEM trunnions.
- Manual or hydraulic tilt options allow operators to maximize productivity based on application and control cost.
- Heavy-duty, Rockland built cylinders deliver years of dependable service.
- Available for all makes of standard gauge and LGP tractors.
- Common sense hose routing prevents snags and delays due to hose damage.



## Coal Blade

*The right choice for moving coal.*

- Rockland coal blade profiles deliver live, rolling loads and are in service around the globe.
- Extended end plates contain load and eliminate side spillage.
- Heavy-duty, alloy steel box frame construction and abrasion resistance moldboard delivers years of dependable service.
- Available with many types of bolt-on cutting edges and end bits.
- Available with skid plates and other custom options based on application.



## Semi-U Blade

*Boost productivity with tool designed for your exact application.*

- Angled wings increase material retention.
- Reversible, heat-treated cutting edges are standard.
- Heavy-duty, alloy steel box frame construction and reinforced endplates guarantee years of dependable service.
- Available with liners, custom spillguards, visibility slots, windows, and many other options upon request.



## Landfill Blade

### *Move trash in a hurry!*

- Delivers up to double the productivity of standard blades in trash applications.
- See what's going on through screened panels at each end of the blade.
- Custom spillguards, profiles, widths, heights, and other options are available.
- High-strength, alloy steel construction extends product life and prevents washboarding and expensive moldboard replacement.
- Equipped with heat-treated reversible cutting edges.



## Reclamation Blade

### *The right tool for mine spoil reclamation.*

- 28° wing angle carries more material with every pass.
- Heavy-duty, alloy steel box frame construction delivers reliable performance year after year.
- Heavy-duty wear resistant moldboard material prevents premature wear.
- Optional blade liners, hardfacing, and other wear parts are available.

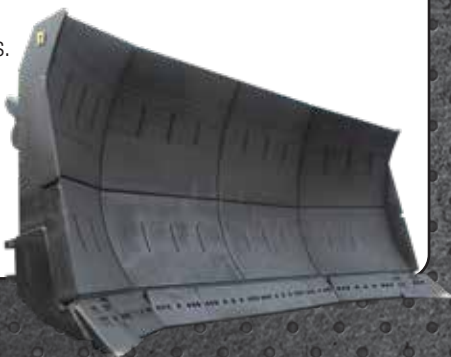

## Woodchip Blade

### *Move massive amounts of woodchips in every pass!*

- Ideal moldboard height and width ratio maximizes the amount of chips moved per pass.
- Extended end plates and moldboard profile contains and delivers a live, rolling load.
- Extended spillguard and the correct blade profile prevents chips from running over the top of the blade.
- Equipped with heat-treated, reversible cutting edges.
- Available with adjustable skid plates, non-stick liners, custom guards, and visibility slots as desired.



# LAND CLEARING BLADES

## You Can Depend On



### ROCKLAND LAND CLEARING BLADES

make quick work of demanding land clearing jobs. Rockland land clearing blades feature high-strength, hardened alloy steel cutting edges and moldboards, and rugged box frame construction.

Rockland clearing blades are available in a wide variety of styles, capacities, and with

many options designed to suit the job at hand. Matching the right tool for the job increases productivity and profits on every pass!

### SA-4 Shear Blade

*Use one tool to shear, clear, and windrow at ground level.*

- Built-in brush guard protects the tractor radiator and helps fell stubborn trees.
- High-strength, quenched and tempered, alloy steel splitter makes quick work of stumps and trees.
- Equipped with high-strength, heat-treated cutting edges that deliver years of dependable service.
- Available with additional wear parts and custom edge options upon request.



### VR Clearing Blade

*The fast way to clear and shear!*

- Tested and proven in the toughest land clearing jobs in the world.
- V-shape design delivers maximum shearing action by using the full power of the dozer.
- Tough, center-mounted splitter is perfect for large trees that can't be sheared in a single pass.
- Comes complete as a trunnion-mounted unit – with reinforced high-strength alloy steel frame.
- Serrated cutting edges run the length of the v-blade – shearing while pushing brush to the side.
- Built-in brush guard keeps brush and debris away from the dozer.



**"With our Rockland VR Blade we get more work done in less time!"**

**– Mississippi Contractor**



**Made in the USA 85**

# ROCKLAND CLEARING RAKE

Experts For Over 65 Years



**ROCKLAND LAND CLEARING RAKES** are where Rockland started. Our first product was the RF-3 rake. 65 years later, it's still the **ONLY** heavy-duty land clearing rake that's covered by a lifetime warranty. The RF-3 and our other land clearing rakes have built a worldwide reputation among contractors who demand quality and value. Every Rockland Rake is designed to perform and built to last. From the BR Blade Rake to the Severe Service RF-3, Rockland rakes are ready to tackle every clearing challenge.

"I've owned Rockland Rakes for over 20 years.  
They simply can't be beat."

– Virginia Contractor



## RF-3 Severe Service Rake



*The toughest rake available – anywhere.*

- Equipped with reversible heavy-duty teeth that can be moved into position as needed.
- The reversible teeth deliver twice the life of a standard rake tooth.
- Move two or three teeth together for easy stumping.
- Backed by Rockland's lifetime warranty.



## Multi-Application Rake

*Ideal for land clearing, stacking, and piling.*

- Fixed, long teeth enable easy digging and piling.
- Rake face and brush guard are a smooth, continuous curve. This delivers maximum rolling action when pushing large piles of debris and brush.
- Reinforced at all critical stress areas for years of dependable service.
- Available with custom tine spacing, custom tine lengths, and additional features upon request.



## BR Blade Rake

*Perfect for the contractor who has to do both dozer work and small site clearing.*

- Perfect for contractors who do not clear enough land to justify a full-time rake.
- Pins quickly into brackets welded to the top of the moldboard.
- Easy-on, easy-off convenience.
- Rugged teeth and a tough boxed-beam mainframe deliver years of dependable service.
- Common models in stock for quick delivery.



## SR Stacking Rake

*Designed specifically for brush clearing.*

- Quickly change a dozer into an efficient brush clearing machine without having to remove the blade.
- Taller than the moldboard for when you need to push large piles of brush.
- Provides extra protection for the front of your dozer.
- Manufactured from high-strength, light-weight alloy steel for years of dependable service.
- Available for all makes and models of machines.



# THE TUFFGATE® TAILGATE



**INCREASES IN CAPACITY EQUALS INCREASES IN PROFIT!** Trucks without a tailgate are typically only loaded to 85-90% of their rated capacity. Tuffgate® Tailgates eliminate this wasted capacity and make sure that you're using the entire dump body on every pass. Tuffgate® Tailgates deliver up to 15% more capacity per load! This increases profits and improves truck ROI. You paid for 100% of the truck, use 100% of it with the Tuffgate® Tailgate!

**TAILGATES ALSO DECREASE MAINTENANCE TIME AND COST.** When loading trucks without tailgates, operators tend to load the truck more toward the front in order to reduce spillage. This results in increased wear, maintenance, and potential dump body damage. By adding a tailgate, the load can be distributed equally. This leads to longer life and reduced maintenance cost.

## Tuffgate® Tailgate

### *Increase haul truck productivity in a big way!*

- Reinforced, heavy-duty design handles shifting loads and stands up to heavy use.
- Three-piece design featuring adjustable hanging brackets and controlled lift points ensure a smooth installation every time.
- Optional seals are available for handling liquid materials.
- Bolt-on tail section requires no welding to install.
- Side body extensions, custom wear plate packages, logos, and many other options are available.
- Available for 20T to 60T rigid frame and articulated haul trucks.



**Optional sideboards shown**



# A ROAD KING SLOPER® CAN DOUBLE YOUR GRADER'S PRODUCTIVITY



**CONTRACTORS** have doubled their grader productivity by using a Rockland Road King Sloper® because with a Road King Sloper® the grader is on the road and out of the ditch. That is a lot faster and much easier on the operator!

"Our Road King Sloper® made a big difference cleaning ditches."

— Georgia Highway Super







### **RKS Road King Sloper®**

#### ***Double your grader's productivity!***

- Use the Road King Sloper® even with grader fully articulated.
- Precisely control oil-flow to all cylinders for accurate blade control.
- Available with 32" of hydraulic side-shift for maximum reach.
- Use optional tailgrading function to eliminate the second pass and save you time!
- Add a moldboard extension for an even bigger productivity boost.
- No-nonsense two year, 4,000 hour warranty.



# DON'T SEE THE ATTACHMENT YOU NEED? No Problem.

**ROCKLAND** custom designs attachments for any application. If you need a tool to help make your work more manageable, productive, and profitable, please give us a call. We would love to work with you to find a better way to help you do more.



"The Rockland Attachment I had designed increased productivity and fit perfectly on my loader."

— West Virginia Contractor





# WEIGHTS OF MATERIALS

## MATERIAL LBS. PER CUBIC YD.

Ashes	1,107
Asphalt, Crushed	1,215
Bagasse	202
Bark, Wood Refuse	405
Beets	1,215
Cement, Portland	2,700
Cement, Mortar	3,645
Cement, Slurry	2,430
Clay, Dry Excavated	1,836
Clay, Wet Excavated	3,078
Coal, Anthracite, Solid	2,538
Coal, Anthracite, Broken	1,863
Coal, Bituminous, Solid	2,268
Coal, Bituminous, Broken	1,404
Coke	702
Concrete, Gravel	4,050
Concrete, Limestone	3,996
Earth, Dry, Packed	2,550
Earth, Loam, Dry, Excavated	2,106
Earth, Wet, Excavated	2,700
Earth, Dense	3,375
Earth, Soft Loose Mud	2,916
Garbage	810
Granite, Solid	4,536
Granite, Broken	2,781
Gravel, Loose, Dry	2,565
Gravel, w/Sand, Natural	3,240
Gravel, Dry, 1/4 to 2 Inch	2,835
Gravel, Wet, 1/4 to 2 Inch	3,375

## MATERIAL LBS. PER CUBIC YD.

Gypsum, Crushed	2,700
Gypsum, Broken	3,051
Gypsum, Pulverized	1,890
Ice, Solid	1,550
Ice, Crushed	999
Limestone, Solid	4,401
Limestone, Lump, Broken	2,605
Limestone, Pulverized	2,349
Phosphate Rock, Broken	2,970
Quartz, Solid	4,455
Quartz, Lump	2,619
Quartz, Sand	2,025
Sand, Wet	3,240
Sand, Dry	2,700
Sandstone, Solid	3,915
Sandstone, Broken	2,538
Sawdust	459
Shale, Solid	4,509
Shale, Broken	2,673
Slag, Solid	3,564
Slag, Broken	2,970
Slag, Crushed, 1/4 Inch	1,998
Slag, Furnace, Granulated	1,620
Slate, Broken	2,808
Slate, Pulverized	2,295
Snow, Compacted	810
Stone, Crushed	2,700
Taconite	4,725
Wheat	1,296

## COMMON CONVERSIONS

STANDARD TO METRIC	METRIC TO STANDARD
1 Inch = 25.4 Millimeters	1 Millimeter = .039 Inches
1 Pound = 0.454 Kilograms	1 Kilogram = 2.205 Pounds
1 Pound/Cubic Yard = 0.593 Kilograms/Cubic Meter	1 Kilogram/Cubic Meter = 1.686 Pound/Cubic Yard
1 PSI = .069 Bar	1 Bar = 12.504 PSI
1 GPM = 3.785 Liters/Minute	1 Liter/Minute = .264 GPM

# CONTACT US

1.800.458.3773

WWW.ROCKLANDMFG.COM

---

**SALES:** sales@rocklandmfg.com

**SERVICE:** service@rocklandmfg.com

**MARKETING:** mktg@rocklandmfg.com

---

## FOLLOW US ON SOCIAL MEDIA



**FIND US ON YOUR  
DESKTOP OR MOBILE DEVICE**



# ROCKLAND<sup>®</sup>



## DO MORE

1.800.458.3773 | [WWW.ROCKLANDMFG.COM](http://WWW.ROCKLANDMFG.COM)

